

Industrial Batteries / Network Power

**Marathon M FT**

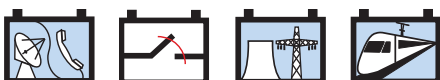

»AGM modular power«



## Industrial Batteries

### The powerful range of Network Power

Energy storage solutions for critical systems that require uninterrupted power supply. GNB® Industrial Power offers powerful batteries for your individual needs. The below table is only indicative and depends on customers' specific applications. For more information please ask a GNB sales representative.

Applica-tions	Battery ranges																			
	Sonnenschein							Marathon		Sprinter			Absolyte	Powerfit	Classic					
	A400/A600	A400 FT	A500	A700	SOLAR	RAIL	Power Cycle	M - FT	M/L/ XL	S	P/XP	XP - FT	GP/GX	S300	GRoE	OCSM	OPzS	Energy Bloc/OGi	Solar	rail
Telecom	●	●	●	●			●	●	●	●	●	●	●			●	●	●		
UPS		●	●	●			●	●	●	●	●	●	●			●		●		
Emergency lighting	●		●					●			●	●	●	●			●	●		
Security	●		●	●							●	●	●	●		●	●			
Utility	●	●		●			●	●	●	●	●	●	●		●	●	●	●		
Railways	●	●	●	●		●	●	●	●	●	●	●	●			●		●		●
Photovoltaic					●		●						●						●	
Universal	●	●	●	●			●	●	●	●	●	●	●	●		●	●	●		

### The GNB Network Power brand overview



- > VRLA batteries (Valve Regulated Lead Acid) in which the electrolyte is fixed in an absorbent glass mat (AGM)
- > Excellent high current capability
- > Very economical
- > Maintenance-free (no topping up)



- > VRLA batteries (Valve Regulated Lead Acid) in which the electrolyte is fixed in a gel (dryfit technology)
- > Inventor of Gel technology
- > Highest reliability, even in non-optimal conditions
- > Particularly suitable for cyclic applications
- > Maintenance-free (no topping up)



- > Conventional lead-acid batteries with liquid electrolyte
- > Extreme reliability, proven over decades
- > Low maintenance



> Further information about service is available on page 14

## Marathon M FT

### The safe storage system with long design life

Designed for durability in telecommunications and electric utility applications, the Marathon M FT series provides high performance and reliability in medium and long duration discharge applications. The location of the terminals on the front (vs. the top) of the battery greatly facilitates the installation and maintenance of the product when placed in a cabinet enclosure or on a standard relay rack tray.

#### Your benefits:

- > **Front terminal design** – easy access for faster installation and maintenance
- > **Durable polypropylene casing (available as flame retardant)** – maintains structural integrity in higher operating temperatures
- > **Short recharging time** – high availability
- > **Optimal energy density** – saves floor space
- > **Completely recyclable** – low CO<sub>2</sub> footprint



#### Specifications:

- > Maintenance-free (no topping up) during the whole service life
- > High-Compression Absorbent Glass Mat (AGM) technology
- > Nominal capacity 35.0 – 200 Ah
- > Design life: »> 12 years– Very Long Life« according to EUROBAT 2015 Classification
- > Central degassing
- > Available as standard or flame retardant version (UL 94-V0)
- > Grid plates with superior lead calcium alloy for excellent corrosion resistance
- > Very low gassing due to internal gas recombination (99 % efficiency)
- > Low self discharge rate, enabling extended storage capability
- > Designed in accordance with IEC 60896-21/-22
- > Approval: Underwriter Laboratories (UL)
- > Trouble-free transportation of operational blocks and cells, no restriction for most rail, road, sea and air transportation (IATA, DGR clause A67)
- > Manufactured in Europe and USA in our ISO 9001 certified production plants



Design life  
> 12 years –  
Very Long  
Life



Nominal  
capacity  
35.0 – 200 Ah



Block battery



Grid plate



Recyclable



Valve regulated  
lead-acid  
batteries



Maintenance  
free (no  
topping up)

## Marathon M FT

### Technical data

#### Technical characteristics and data

Type	Part number	Nom. voltage V	Nominal capacity C <sub>10</sub> 1.80 Vpc 20°C Ah	Capacity C <sub>8</sub> 1.75 Vpc 25°C Ah	Capacity C <sub>3</sub> 1.70 Vpc 20°C Ah	Capacity C <sub>1</sub> 1.60 Vpc 20°C Ah	Length (l) mm	Width (b/w) mm	Height (h1) max. mm	Weight approx. kg	Internal resistance mOhm	Short circuit current A	Terminal
M6V200FT	NAMT060200HM0FA	6	200	200	167	140	361	132	250	34.0	1.7	3461	F-M6
M12V35FT	NAMF120035HM0MA	12	35.0	35.0	30.8	27.2	280	107	189	14.0	11.0	1149	M-M6-90°
M12V50FT	NAMF120050HM0MA	12	47.0	48.0	41.1	35.2	280	107	231	18.0	8.2	1547	M-M6-90°
M12V60FT	NAMF120060HM0MA	12	59.0	59.0	50.2	41.3	280	107	263	23.0	7.0	1794	M-M6-90°
M12V90FT	NAMF120090HM0FA	12	86.0	86.0	75.2	65.3	395	105	270	31.0	5.1	2440	F-M6-90°
M12V105FT	NAMF120105HM0FA	12	100	104	86.6	71.3	511	110	238	35.8	4.9	2554	F-M6-90°
M12V125FT	NAMF120125HM0FA	12	121	125	112	89.4	559	124	283	47.6	4.7	2640	F-M6-90°
M12V155FT	NAMF120155HM0FA	12	150	155	131	104	559	124	283	53.8	3.8	3292	F-M6-90°
M12V180FT	NAMF120180VM0FA	12	175	180	148	120	559	125	318	60.3	3.0	4147	F-M6-90°
<b>NEW</b> M12V190FT	NAMF120190HM0FA	12	190	193	159	128	559	125	318	60.0	3.4	3653	F-M6-90°

Installed length of type M6V200FT: 376 mm

#### Container, terminal and torque

- > **Container:** - UL 94-HB = Polypropylene (PP)
- UL 94-V0 = Polypropylene (PP)

Figures are also valid for UL 94-V0 version.  
Change »H« to »V« in the part number. E.g.:

- > **Standard:** NAMF120035 **H** M0MA
- > **UL 94-V0:** NAMF120035 **V** M0MA

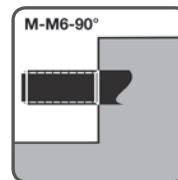

6 Nm

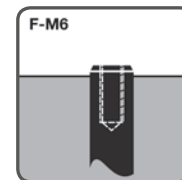

11 Nm

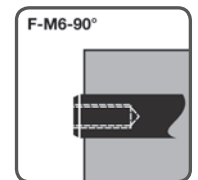

11 Nm

# Marathon M FT

## Drawings Marathon M FT

**M6V200FT**

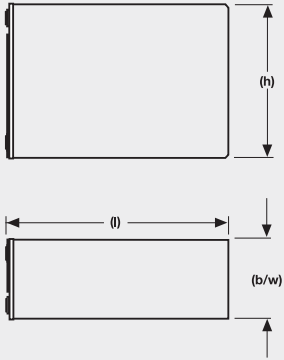

**M12V35FT**

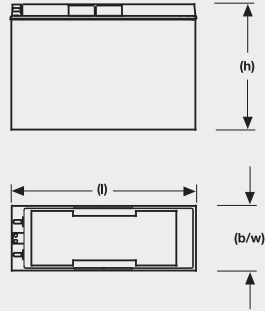

**M12V50FT**

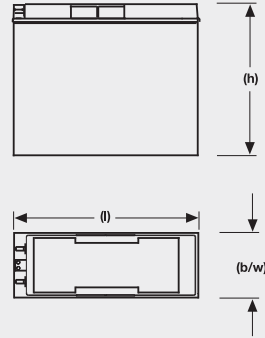

**M12V60FT**

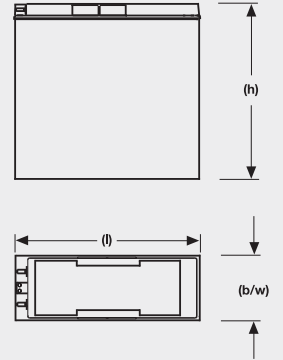

**M12V90FT**

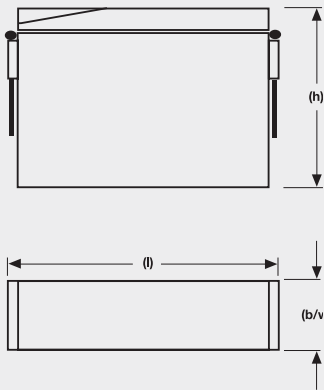

**M12V105FT**

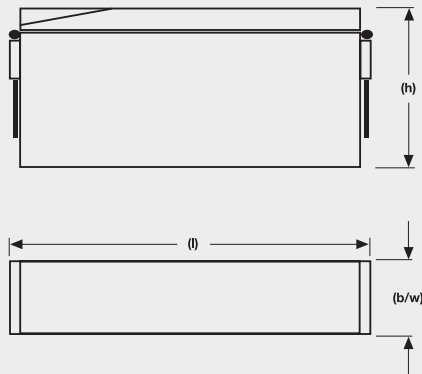

**M12V125FT -  
M12V190FT**

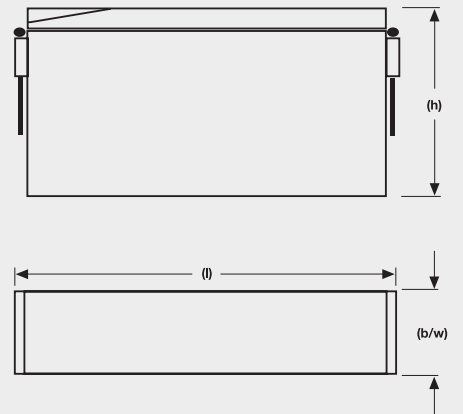

Not to scale!

## Marathon M FT

### Constant current discharge

#### 1.94 Vpc – Discharge in A at 20 °C

Type	Part number	3 min	5 min	10 min	15 min	30 min	1 h	1,5 h	2 h	3 h	5 h	8 h	10 h	12 h	24 h
M6V200FT	NAMT060200HMOFA <sup>1</sup>	131	131	131	131	115	90.7	67.7	54.9	40.3	27.3	18.8	15.4	13.1	7.05
M12V35FT	NAMF120035HMOMA <sup>1</sup>	45.6	45.6	45.6	45.6	32.2	19.9	14.0	10.9	7.72	4.96	3.30	2.72	2.32	1.27
M12V50FT	NAMF120050HMOMA <sup>1</sup>	67.3	67.3	67.3	67.3	43.6	26.1	18.7	14.8	10.5	6.72	4.41	3.61	3.06	1.64
M12V60FT	NAMF120060HMOMA <sup>1</sup>	72.9	72.9	72.9	72.9	49.7	30.5	22.1	17.5	12.7	8.45	5.63	4.61	3.91	2.10
M12V90FT	NAMF120090HMOFA <sup>1</sup>	100	100	100	100	73.0	47.0	33.9	26.8	19.5	12.7	8.37	6.86	5.84	3.15
M12V105FT	NAMF120105HMOFA <sup>1</sup>	121	121	121	121	79.9	52.4	38.3	30.6	22.3	14.9	9.74	7.96	6.75	3.60
M12V125FT	NAMF120125HMOFA <sup>1</sup>	97.5	97.5	97.5	97.5	77.8	62.1	45.6	36.6	27.0	17.3	11.4	9.47	8.00	4.22
M12V155FT	NAMF120155HMOFA <sup>1</sup>	122	122	122	122	95.1	74.0	56.2	46.3	33.5	21.8	14.4	11.7	9.96	5.28
M12V180FT	NAMF120180VMOFA	127	127	127	127	127	82.6	63.0	50.3	37.2	24.8	16.7	13.6	11.5	6.11
M12V190FT	NAMF120190HMOFA <sup>1</sup>	151	149	142	135	115	87.4	66.7	54.3	40.2	26.6	18.0	14.8	12.7	6.73

#### 1.92 Vpc – Discharge in A at 20 °C

Type	Part number	3 min	5 min	10 min	15 min	30 min	1 h	1,5 h	2 h	3 h	5 h	8 h	10 h	12 h	24 h
M6V200FT	NAMT060200HMOFA <sup>1</sup>	159	159	159	159	133	97.7	72.7	59.0	43.1	29.0	20.0	16.3	13.9	7.47
M12V35FT	NAMF120035HMOMA <sup>1</sup>	50.2	50.2	50.2	50.2	34.4	21.3	15.0	11.7	8.25	5.28	3.50	2.88	2.46	1.34
M12V50FT	NAMF120050HMOMA <sup>1</sup>	73.0	73.0	73.0	73.0	46.0	26.3	20.1	15.9	11.2	7.10	4.66	3.82	3.24	1.74
M12V60FT	NAMF120060HMOMA <sup>1</sup>	79.2	79.2	79.2	79.2	53.7	33.1	23.8	18.9	13.6	9.11	5.98	4.89	4.16	2.23
M12V90FT	NAMF120090HMOFA <sup>1</sup>	110	110	110	110	80.0	50.5	36.2	28.5	20.4	13.4	8.86	7.26	6.17	3.33
M12V105FT	NAMF120105HMOFA <sup>1</sup>	132	132	132	132	86.0	55.8	40.6	32.3	23.5	15.8	10.3	8.42	7.13	3.79
M12V125FT	NAMF120125HMOFA <sup>1</sup>	125	125	125	125	91.7	67.3	49.4	39.7	29.1	18.5	12.1	10.1	8.53	4.48
M12V155FT	NAMF120155HMOFA <sup>1</sup>	149	149	149	149	108	78.8	59.7	49.0	35.1	23.0	15.3	12.5	10.5	5.60
M12V180FT	NAMF120180VMOFA	137	137	137	137	137	90.8	68.0	54.5	39.9	26.3	17.9	14.5	12.3	6.49
M12V190FT	NAMF120190HMOFA <sup>1</sup>	180	176	166	156	130	96.0	72.7	58.8	43.1	28.6	19.3	15.9	13.6	7.20

#### 1.90 Vpc – Discharge in A at 20 °C

Type	Part number	3 min	5 min	10 min	15 min	30 min	1 h	1,5 h	2 h	3 h	5 h	8 h	10 h	12 h	24 h
M6V200FT	NAMT060200HMOFA <sup>1</sup>	187	187	187	187	150	105	77.9	63.0	45.8	30.6	21.1	17.2	14.7	7.92
M12V35FT	NAMF120035HMOMA <sup>1</sup>	56.4	56.4	56.4	56.4	36.8	22.8	16.0	12.5	8.78	5.61	3.71	3.05	2.60	1.41
M12V50FT	NAMF120050HMOMA <sup>1</sup>	76.0	76.0	76.0	76.0	47.0	26.7	21.3	16.9	11.9	7.52	4.92	4.02	3.41	1.83
M12V60FT	NAMF120060HMOMA <sup>1</sup>	85.7	85.7	85.7	85.7	55.8	35.7	25.6	20.2	14.5	9.55	6.35	5.19	4.40	2.36
M12V90FT	NAMF120090HMOFA <sup>1</sup>	115	115	115	115	84.0	53.9	38.5	30.3	21.6	14.1	9.33	7.65	6.51	3.52
M12V105FT	NAMF120105HMOFA <sup>1</sup>	141	141	141	141	91.6	59.4	42.9	34.1	24.6	16.4	10.9	8.90	7.52	3.97
M12V125FT	NAMF120125HMOFA <sup>1</sup>	152	152	152	152	105	72.6	52.9	42.3	31.1	19.6	12.9	10.5	9.00	4.84
M12V155FT	NAMF120155HMOFA <sup>1</sup>	170	170	170	170	122	83.9	63.4	51.9	37.0	24.1	16.3	13.3	11.2	5.91
M12V180FT	NAMF120180VMOFA	146	146	146	146	146	96.6	73.0	58.2	42.4	27.7	18.9	15.3	12.9	6.79
M12V190FT	NAMF120190HMOFA <sup>1</sup>	210	205	191	178	145	102	77.3	62.9	45.5	30.1	20.3	16.8	14.4	7.60

#### 1.87 Vpc – Discharge in A at 20 °C

Type	Part number	3 min	5 min	10 min	15 min	30 min	1 h	1,5 h	2 h	3 h	5 h	8 h	10 h	12 h	24 h
M6V200FT	NAMT060200HMOFA <sup>1</sup>	231	231	231	231	175	115	84.0	66.9	48.6	32.4	22.4	18.3	15.5	8.29
M12V35FT	NAMF120035HMOMA <sup>1</sup>	61.2	61.2	61.2	61.2	39.2	24.3	17.0	13.2	9.29	5.92	3.91	3.21	2.73	1.48
M12V50FT	NAMF120050HMOMA <sup>1</sup>	78.0	78.0	78.0	78.0	48.0	27.0	22.3	17.6	12.5	7.93	5.20	4.26	3.61	1.94
M12V60FT	NAMF120060HMOMA <sup>1</sup>	90.0	90.0	90.0	90.0	57.0	37.4	26.9	21.2	15.2	10.0	6.69	5.46	4.63	2.47
M12V90FT	NAMF120090HMOFA <sup>1</sup>	120	120	120	120	87.0	57.4	40.8	32.0	23.1	14.7	9.77	8.03	6.84	3.71
M12V105FT	NAMF120105HMOFA <sup>1</sup>	147	147	147	147	97.9	62.6	45.1	35.7	25.8	17.0	11.4	9.34	7.89	4.17
M12V125FT	NAMF120125HMOFA <sup>1</sup>	169	169	169	169	115	78.0	56.5	44.9	33.0	20.8	13.6	11.1	9.48	5.08
M12V155FT	NAMF120155HMOFA <sup>1</sup>	196	196	196	196	136	89.5	67.2	54.8	39.0	25.3	17.0	13.9	11.7	6.18
M12V180FT	NAMF120180VMOFA	224	224	224	224	159	103	77.0	61.1	44.4	29.2	19.9	16.1	13.6	7.17
M12V190FT	NAMF120190HMOFA <sup>1</sup>	270	260	237	216	164	109	82.0	65.9	47.9	31.9	21.4	17.8	15.2	8.00

<sup>1</sup> Discharge data are also valid for other containers.

## Marathon M FT

### Constant current discharge

#### 1.85 Vpc – Discharge in A at 20 °C

Type	Part number	3 min	5 min	10 min	15 min	30 min	1 h	1,5 h	2 h	3 h	5 h	8 h	10 h	12 h	24 h
M6V200FT	NAMT060200HMOFA <sup>1</sup>	345	325	283	250	186	122	88.3	70.1	50.6	33.5	23.0	18.9	16.0	8.54
M12V35FT	NAMF120035HMOMA <sup>1</sup>	64.8	64.8	64.8	64.8	40.9	25.3	17.7	13.8	9.64	6.13	4.04	3.32	2.82	1.52
M12V50FT	NAMF120050HMOMA <sup>1</sup>	180	147	102	80.0	48.8	27.4	23.1	18.2	12.9	8.20	5.38	4.41	3.74	2.01
M12V60FT	NAMF120060HMOMA <sup>1</sup>	190	160	118	94.0	58.5	38.5	27.7	21.8	15.7	10.3	6.92	5.64	4.78	2.54
M12V90FT	NAMF120090HMOFA <sup>1</sup>	207	189	150	126	90.0	59.5	42.3	33.2	23.5	15.1	10.0	8.28	7.07	3.87
M12V105FT	NAMF120105HMOFA <sup>1</sup>	265	240	191	154	101	64.7	46.5	36.9	26.5	17.5	11.7	9.59	8.12	4.32
M12V125FT	NAMF120125HMOFA <sup>1</sup>	175	175	175	175	119	79.1	57.9	46.4	34.3	21.6	14.1	11.5	9.80	5.24
M12V155FT	NAMF120155HMOFA <sup>1</sup>	324	290	245	210	147	92.8	69.6	56.8	40.3	26.1	17.6	14.3	12.1	6.35
M12V180FT	NAMF120180VMOFA <sup>1</sup>	239	239	239	239	166	107	79.0	63.0	45.6	30.0	20.5	16.6	14.0	7.37
M12V190FT	NAMF120190HMOFA <sup>1</sup>	382	350	293	253	178	113	84.7	68.0	49.3	32.6	22.0	18.3	15.6	8.20

#### 1.83 Vpc – Discharge in A at 20 °C

Type	Part number	3 min	5 min	10 min	15 min	30 min	1 h	1,5 h	2 h	3 h	5 h	8 h	10 h	12 h	24 h
M6V200FT	NAMT060200HMOFA <sup>1</sup>	385	360	309	270	197	126	90.8	71.9	51.7	34.2	23.3	19.2	16.3	8.66
M12V35FT	NAMF120035HMOMA <sup>1</sup>	66.9	66.9	66.9	66.9	41.8	25.7	18.0	14.0	9.80	6.23	4.11	3.37	2.87	1.55
M12V50FT	NAMF120050HMOMA <sup>1</sup>	197	157	106	82.0	49.6	27.7	23.3	18.4	13.1	8.38	5.48	4.48	3.80	2.03
M12V60FT	NAMF120060HMOMA <sup>1</sup>	205	173	125	98.0	60.0	39.3	28.2	22.2	15.9	10.5	7.03	5.73	4.85	2.57
M12V90FT	NAMF120090HMOFA <sup>1</sup>	220	200	160	133	92.0	61.0	43.3	34.0	23.9	15.3	10.2	8.40	7.17	3.92
M12V105FT	NAMF120105HMOFA <sup>1</sup>	295	260	200	163	104	66.3	47.6	37.7	27.1	17.9	12.0	9.79	8.28	4.40
M12V125FT	NAMF120125HMOFA <sup>1</sup>	186	186	186	186	124	81.7	59.6	47.7	35.2	22.1	14.4	11.8	10.0	5.34
M12V155FT	NAMF120155HMOFA <sup>1</sup>	355	315	257	220	154	95.8	71.5	58.1	41.1	26.7	17.9	14.5	12.3	6.50
M12V180FT	NAMF120180VMOFA <sup>1</sup>	254	254	254	254	172	110	80.0	64.5	46.5	30.7	20.9	17.0	14.3	7.46
M12V190FT	NAMF120190HMOFA <sup>1</sup>	420	381	312	266	186	116	86.7	69.6	50.2	33.2	22.5	18.6	15.9	8.30

#### 1.80 Vpc – Discharge in A at 20 °C

Type	Part number	3 min	5 min	10 min	15 min	30 min	1 h	1,5 h	2 h	3 h	5 h	8 h	10 h	12 h	24 h
M6V200FT	NAMT060200HMOFA <sup>1</sup>	425	395	335	290	208	132	95.1	75.1	53.8	35.3	24.0	19.9	16.8	8.90
M12V35FT	NAMF120035HMOMA <sup>1</sup>	70.2	70.2	70.2	70.2	43.2	26.3	18.4	14.2	10.0	6.38	4.21	3.46	2.94	1.58
M12V50FT	NAMF120050HMOMA <sup>1</sup>	212	168	110	84.0	50.3	28.0	23.8	18.7	13.2	8.64	5.66	4.68	3.89	2.05
M12V60FT	NAMF120060HMOMA <sup>1</sup>	220	185	130	101	61.5	39.6	28.5	22.5	16.2	10.8	7.21	5.87	4.96	2.62
M12V90FT	NAMF120090HMOFA <sup>1</sup>	237	215	171	140	94.0	63.0	44.7	35.0	24.5	15.7	10.4	8.57	7.31	3.99
M12V105FT	NAMF120105HMOFA <sup>1</sup>	320	280	214	170	109	68.3	49.0	38.7	27.8	18.3	12.2	10.0	8.47	4.48
M12V125FT	NAMF120125HMOFA <sup>1</sup>	204	204	204	204	132	85.1	61.8	49.2	36.3	22.8	14.8	12.1	10.3	5.46
M12V155FT	NAMF120155HMOFA <sup>1</sup>	385	340	270	230	161	99.8	73.8	59.6	42.2	27.4	18.4	14.9	12.6	6.64
M12V180FT	NAMF120180VMOFA <sup>1</sup>	273	273	273	273	179	113	83.0	65.9	47.6	31.3	21.4	17.3	14.6	7.66
M12V190FT	NAMF120190HMOFA <sup>1</sup>	458	410	330	278	193	119	88.7	71.2	51.4	34.1	23.0	19.0	16.2	8.50

#### 1.78 Vpc – Discharge in A at 20 °C

Type	Part number	3 min	5 min	10 min	15 min	30 min	1 h	1,5 h	2 h	3 h	5 h	8 h	10 h	12 h	24 h
M6V200FT	NAMT060200HMOFA <sup>1</sup>	475	435	362	309	216	134	96.5	76.3	54.6	35.7	24.2	20.0	16.9	8.95
M12V35FT	NAMF120035HMOMA <sup>1</sup>	71.4	71.4	71.4	71.4	43.6	26.4	18.4	14.3	10.0	6.42	4.24	3.48	2.97	1.61
M12V50FT	NAMF120050HMOMA <sup>1</sup>	225	175	114	85.5	50.8	28.2	24.0	18.8	13.3	8.70	5.70	4.68	3.92	2.06
M12V60FT	NAMF120060HMOMA <sup>1</sup>	236	193	134	104	62.4	39.6	28.6	22.7	16.4	10.8	7.26	5.91	5.00	2.64
M12V90FT	NAMF120090HMOFA <sup>1</sup>	265	233	179	144	96.0	63.6	45.0	35.2	24.7	15.8	10.4	8.62	7.35	4.01
M12V105FT	NAMF120105HMOFA <sup>1</sup>	360	310	230	185	115	69.3	49.7	39.2	28.1	18.5	12.4	10.1	8.57	4.53
M12V125FT	NAMF120125HMOFA <sup>1</sup>	214	214	214	214	136	86.6	62.7	49.8	36.7	23.0	15.0	12.2	10.4	5.53
M12V155FT	NAMF120155HMOFA <sup>1</sup>	410	360	285	240	165	101	74.9	60.3	42.8	27.7	18.6	15.1	12.7	6.72
M12V180FT	NAMF120180VMOFA <sup>1</sup>	286	286	286	286	182	114	84.5	66.6	48.0	31.6	21.6	17.5	14.7	7.66
M12V190FT	NAMF120190HMOFA <sup>1</sup>	489	433	346	291	197	120	90.0	71.9	51.8	34.4	23.2	19.2	16.4	8.60

<sup>1</sup> Discharge data are also valid for other containers.

## Marathon M FT

### Constant current discharge

#### 1.75 Vpc – Discharge in A at 20 °C

Type	Part number	3 min	5 min	10 min	15 min	30 min	1 h	1.5 h	2 h	3 h	5 h	8 h	10 h	12 h	24 h
M6V200FT	NAMT060200HM0FA <sup>1</sup>	515	470	383	323	220	135	97.2	76.9	55.1	36.2	24.5	20.2	17.1	9.04
M12V35FT	NAMF120035HM0MA <sup>1</sup>	72.6	72.6	72.6	72.6	44.0	26.4	18.5	14.3	10.1	6.55	4.32	3.53	2.99	1.59
M12V50FT	NAMF120050HM0MA <sup>1</sup>	235	180	117	87.0	51.3	28.5	24.3	19.0	13.5	8.82	5.76	4.69	3.96	2.08
M12V60FT	NAMF120060HM0MA <sup>1</sup>	255	203	136	106	63.2	40.1	28.9	22.9	16.5	10.9	7.34	5.97	5.05	2.66
M12V90FT	NAMF120090HM0FA <sup>1</sup>	285	248	185	148	98.0	64.0	45.4	35.5	24.9	15.9	10.5	8.68	7.40	4.03
M12V105FT	NAMF120105HM0FA <sup>1</sup>	360	310	230	185	115	70.0	50.2	39.7	28.5	18.7	12.6	10.2	8.68	4.55
M12V125FT	NAMF120125HM0FA <sup>1</sup>	233	233	233	233	141	88.1	63.6	50.4	37.1	23.3	15.2	12.4	10.5	5.60
M12V155FT	NAMF120155HM0FA <sup>1</sup>	433	380	300	250	169	103	75.7	60.8	43.2	28.0	18.9	15.3	12.9	6.79
M12V180FT	NAMF120180VM0FA	357	357	357	302	184	115	85.5	67.3	48.4	32.0	21.8	17.6	14.9	7.76
M12V190FT	NAMF120190HM0FA <sup>1</sup>	523	459	363	302	204	122	90.7	72.6	52.2	34.8	23.4	19.3	16.5	8.70

#### 1.73 Vpc – Discharge in A at 20 °C

Type	Part number	3 min	5 min	10 min	15 min	30 min	1 h	1.5 h	2 h	3 h	5 h	8 h	10 h	12 h	24 h
M6V200FT	NAMT060200HM0FA <sup>1</sup>	540	490	397	333	223	136	97.9	77.4	55.4	36.5	24.7	20.2	17.1	9.06
M12V35FT	NAMF120035HM0MA <sup>1</sup>	73.1	73.1	73.1	73.1	44.4	26.5	18.5	14.3	10.2	6.64	4.34	3.54	3.00	1.60
M12V50FT	NAMF120050HM0MA <sup>1</sup>	241	185	120	89.0	51.6	28.7	24.4	19.1	13.6	8.90	5.79	4.71	3.97	2.08
M12V60FT	NAMF120060HM0MA <sup>1</sup>	270	212	139	107	64.0	40.2	29.0	23.0	16.6	11.0	7.37	6.00	5.06	2.66
M12V90FT	NAMF120090HM0FA <sup>1</sup>	314	265	192	151	100	64.4	45.5	35.6	24.9	15.9	10.5	8.70	7.42	4.04
M12V105FT	NAMF120105HM0FA <sup>1</sup>	380	330	240	189	116	70.5	50.6	40.0	28.6	18.8	12.7	10.3	8.71	4.56
M12V125FT	NAMF120125HM0FA <sup>1</sup>	236	236	236	236	143	88.7	64.1	50.8	37.3	23.5	15.3	12.5	10.5	5.63
M12V155FT	NAMF120155HM0FA <sup>1</sup>	465	405	310	258	173	104	76.2	61.2	43.5	28.2	18.9	15.4	12.9	6.80
M12V180FT	NAMF120180VM0FA	368	368	368	311	186	116	86.0	68.1	48.8	32.1	21.9	17.7	14.9	7.76
M12V190FT	NAMF120190HM0FA <sup>1</sup>	562	490	375	312	209	123	91.3	73.6	52.8	34.9	23.5	19.4	16.6	8.70

#### 1.70 Vpc – Discharge in A at 20 °C

Type	Part number	3 min	5 min	10 min	15 min	30 min	1 h	1.5 h	2 h	3 h	5 h	8 h	10 h	12 h	24 h
M6V200FT	NAMT060200HM0FA <sup>1</sup>	565	510	407	340	226	137	98.4	77.8	55.7	36.7	24.8	20.3	17.2	9.09
M12V35FT	NAMF120035HM0MA <sup>1</sup>	74.0	74.0	74.0	74.0	44.6	26.7	18.6	14.4	10.2	6.68	4.36	3.56	3.02	1.61
M12V50FT	NAMF120050HM0MA <sup>1</sup>	250	190	123	91.0	52.3	29.1	24.5	19.2	13.6	8.94	5.84	4.74	4.00	2.09
M12V60FT	NAMF120060HM0MA <sup>1</sup>	280	220	142	108	64.5	40.4	29.2	23.1	16.7	11.0	7.42	6.03	5.09	2.67
M12V90FT	NAMF120090HM0FA <sup>1</sup>	340	280	200	155	102	64.7	45.7	35.7	25.0	16.0	10.6	8.74	7.45	4.06
M12V105FT	NAMF120105HM0FA <sup>1</sup>	410	345	245	193	118	71.2	51.1	40.4	28.8	18.9	12.7	10.3	8.75	4.58
M12V125FT	NAMF120125HM0FA <sup>1</sup>	241	241	241	241	147	89.6	64.6	51.2	37.5	23.7	15.4	12.6	10.6	5.67
M12V155FT	NAMF120155HM0FA <sup>1</sup>	505	430	320	265	176	105	76.9	61.7	43.8	28.4	19.0	15.4	13.0	6.83
M12V180FT	NAMF120180VM0FA	384	384	384	323	188	117	86.5	68.6	49.2	32.3	22.0	17.8	15.0	7.85
M12V190FT	NAMF120190HM0FA <sup>1</sup>	611	520	387	320	213	124	92.0	74.1	53.0	35.1	23.6	19.5	16.7	8.80

#### 1.67 Vpc – Discharge in A at 20 °C

Type	Part number	3 min	5 min	10 min	15 min	30 min	1 h	1.5 h	2 h	3 h	5 h	8 h	10 h	12 h	24 h
M6V200FT	NAMT060200HM0FA	600	535	422	348	228	138	99.1	78.2	56.0	36.9	25.0	20.5	17.3	9.12
M12V35FT	NAMF120035HM0MA <sup>1</sup>	74.9	74.9	74.9	74.9	44.8	26.8	18.7	14.5	10.3	6.72	4.38	3.58	3.03	1.61
M12V50FT	NAMF120050HM0MA <sup>1</sup>	259	195	126	93.0	52.9	29.4	24.6	19.3	13.7	9.00	5.88	4.77	4.02	2.10
M12V60FT	NAMF120060HM0MA <sup>1</sup>	287	226	144	110	65.0	40.7	29.4	23.2	16.8	11.1	7.46	6.06	5.12	2.68
M12V90FT	NAMF120090HM0FA <sup>1</sup>	365	300	210	160	105	64.9	45.9	35.9	25.2	16.1	10.6	8.77	7.48	4.07
M12V105FT	NAMF120105HM0FA <sup>1</sup>	430	360	250	196	119	72.0	51.6	40.7	29.1	19.0	12.8	10.4	8.79	4.59
M12V125FT	NAMF120125HM0FA <sup>1</sup>	248	248	248	248	150	90.6	65.2	51.7	37.6	23.9	15.5	12.7	10.7	5.72
M12V155FT	NAMF120155HM0FA <sup>1</sup>	530	450	330	270	179	106	77.6	62.2	44.2	28.5	19.1	15.5	13.1	6.86
M12V180FT	NAMF120180VM0FA	399	399	399	327	190	118	87.0	69.0	49.4	32.3	22.1	17.9	15.0	7.85
M12V190FT	NAMF120190HM0FA <sup>1</sup>	641	544	399	326	215	125	92.7	74.5	53.3	35.2	23.7	19.6	16.8	8.80

<sup>1</sup> Discharge data are also valid for other containers.



## Marathon M FT

### Constant current discharge

#### 1.65 Vpc – Discharge in A at 20 °C

Type	Part number	3 min	5 min	10 min	15 min	30 min	1 h	1,5 h	2 h	3 h	5 h	8 h	10 h	12 h	24 h
M6V200FT	NAMT060200HM0FA <sup>1</sup>	640	560	435	357	231	139	99.8	78.6	56.3	36.9	25.0	20.5	17.3	9.14
M12V35FT	NAMF120035HMOMA <sup>1</sup>	75.5	75.5	75.5	75.5	45.0	26.9	18.7	14.5	10.3	6.75	4.40	3.59	3.04	1.62
M12V50FT	NAMF120050HMOMA <sup>1</sup>	264	199	129	95.0	53.5	29.6	24.7	19.3	13.8	9.08	5.92	4.80	4.04	2.11
M12V60FT	NAMF120060HMOMA <sup>1</sup>	295	232	147	111	65.5	40.8	29.4	23.3	16.8	11.1	7.49	6.09	5.13	2.69
M12V90FT	NAMF120090HM0FA <sup>1</sup>	390	315	215	165	108	65.1	46.0	36.0	25.2	16.1	10.6	8.79	7.49	4.08
M12V105FT	NAMF120105HM0FA <sup>1</sup>	445	370	258	197	120	72.6	52.0	41.0	29.2	19.0	12.9	10.4	8.82	4.60
M12V125FT	NAMF120125HM0FA <sup>1</sup>	250	250	250	250	152	91.2	65.7	52.0	37.7	24.0	15.6	12.7	10.8	5.75
M12V155FT	NAMF120155HM0FA <sup>1</sup>	555	470	340	274	180	106	78.0	62.5	44.4	28.6	19.2	15.6	13.1	6.88
M12V180FT	NAMF120180VM0FA	409	409	409	329	190	119	87.2	69.2	49.5	32.3	22.1	17.9	15.1	7.85
M12V190FT	NAMF120190HM0FA <sup>1</sup>	671	568	411	331	216	125	93.3	74.7	53.5	35.2	23.7	19.7	16.9	8.80

#### 1.60 Vpc – Discharge in A at 20 °C

Type	Part number	3 min	5 min	10 min	15 min	30 min	1 h	1,5 h	2 h	3 h	5 h	8 h	10 h	12 h	24 h
M6V200FT	NAMT060200HM0FA <sup>1</sup>	680	590	450	365	233	139	99.7	78.6	56.3	36.9	25.0	20.5	17.3	9.14
M12V35FT	NAMF120035HMOMA <sup>1</sup>	75.5	75.5	75.5	75.5	45.0	26.9	18.7	14.5	10.3	6.75	4.40	3.59	3.04	1.62
M12V50FT	NAMF120050HMOMA <sup>1</sup>	270	202	131	97.0	54.0	30.0	24.7	19.3	13.8	9.08	5.92	4.80	4.04	2.11
M12V60FT	NAMF120060HMOMA <sup>1</sup>	305	240	150	112	66.0	40.8	29.4	23.3	16.8	11.1	7.49	6.09	5.13	2.69
M12V90FT	NAMF120090HM0FA <sup>1</sup>	400	330	220	170	110	65.1	46.0	36.0	25.2	16.1	10.6	8.79	7.49	4.08
M12V105FT	NAMF120105HM0FA <sup>1</sup>	460	380	260	201	122	73.4	52.0	41.0	29.2	19.0	12.9	10.4	8.82	4.60
M12V125FT	NAMF120125HM0FA <sup>1</sup>	250	250	250	250	152	91.2	65.7	52.0	37.7	24.0	15.6	12.7	10.8	5.75
M12V155FT	NAMF120155HM0FA <sup>1</sup>	600	495	350	277	181	106	78.0	62.5	44.4	28.6	19.2	15.6	13.1	6.88
M12V180FT	NAMF120180VM0FA	431	431	431	333	191	119	87.5	69.6	49.8	32.5	22.2	18.0	15.1	7.85
M12V190FT	NAMF120190HM0FA <sup>1</sup>	725	598	423	335	219	128	94.0	75.2	53.8	35.4	23.8	19.8	16.9	8.80

<sup>1</sup> Discharge data are also valid for other containers.

## Marathon M FT

### Constant power discharge

#### 1.94 V<sub>pc</sub> – Discharge in W/block at 20 °C

Type	Part number	3 min	5 min	10 min	15 min	30 min	1 h	1,5 h	2 h	3 h	5 h	8 h	10 h	12 h	24 h
M6V200FT	NAMT060200HM0FA <sup>1</sup>	1030	1030	1030	1030	804	551	416	341	247	164	112	91.9	77.8	41.3
M12V35FT	NAMF120035HM0MA <sup>1</sup>	564	564	564	564	377	231	165	130	92.5	59.8	40.0	33.0	28.3	15.6
M12V50FT	NAMF120050HM0MA <sup>1</sup>	731	731	731	731	492	311	232	184	129	82.5	54.6	44.9	38.3	20.8
M12V60FT	NAMF120060HM0MA <sup>1</sup>	882	882	882	882	597	365	265	211	153	102	67.5	55.0	46.6	24.6
M12V90FT	NAMF120090HM0FA <sup>1</sup>	1180	1180	1180	1180	870	562	407	324	235	156	103	84.5	71.5	37.9
M12V105FT	NAMF120105HM0FA <sup>1</sup>	1250	1250	1250	1250	968	612	443	352	255	170	112	91.8	78.0	41.9
M12V125FT	NAMF120125HM0FA <sup>1</sup>	1159	1159	1159	1159	1159	729	533	427	312	210	146	118	99.7	51.8
M12V155FT	NAMF120155HM0FA <sup>1</sup>	1337	1337	1337	1337	1309	862	649	530	385	257	174	142	121	64.6
M12V180FT	NAMF120180VM0FA	1454	1454	1454	1454	1454	997	718	570	417	277	190	159	138	79.2
M12V190FT	NAMF120190HM0FA <sup>1</sup>	1631	1631	1631	1631	1571	1076	765	616	450	299	205	172	149	85.6

#### 1.92 V<sub>pc</sub> – Discharge in W/block at 20 °C

Type	Part number	3 min	5 min	10 min	15 min	30 min	1 h	1,5 h	2 h	3 h	5 h	8 h	10 h	12 h	24 h
M6V200FT	NAMT060200HM0FA <sup>1</sup>	1110	1110	1110	1110	857	585	443	363	262	173	118	96.9	82.1	43.8
M12V35FT	NAMF120035HM0MA <sup>1</sup>	601	601	601	601	399	247	176	139	98.3	63.4	42.4	35.0	29.9	16.5
M12V50FT	NAMF120050HM0MA <sup>1</sup>	798	798	798	798	525	331	245	196	137	87.4	57.7	47.4	40.3	21.9
M12V60FT	NAMF120060HM0MA <sup>1</sup>	1017	1017	1017	1017	644	392	283	224	162	107	71.8	58.5	49.4	26.1
M12V90FT	NAMF120090HM0FA <sup>1</sup>	1290	1290	1290	1290	944	596	430	342	247	164	109	88.9	75.2	39.8
M12V105FT	NAMF120105HM0FA <sup>1</sup>	1526	1526	1526	1526	1025	651	470	373	269	180	118	97.0	82.4	44.2
M12V125FT	NAMF120125HM0FA <sup>1</sup>	1237	1237	1237	1237	1237	778	567	453	330	222	155	125	105	54.8
M12V155FT	NAMF120155HM0FA <sup>1</sup>	1626	1626	1626	1626	1407	916	684	556	403	269	184	150	127	67.9
M12V180FT	NAMF120180VM0FA	1554	1554	1554	1554	1554	1052	771	610	444	293	200	167	144	82.1
M12V190FT	NAMF120190HM0FA <sup>1</sup>	1983	1983	1983	1983	1678	1136	818	659	480	317	216	180	156	88.7

#### 1.90 V<sub>pc</sub> – Discharge in W/block at 20 °C

Type	Part number	3 min	5 min	10 min	15 min	30 min	1 h	1,5 h	2 h	3 h	5 h	8 h	10 h	12 h	24 h
M6V200FT	NAMT060200HM0FA <sup>1</sup>	1200	1200	1200	1200	920	620	470	386	277	182	125	102	86.6	46.0
M12V35FT	NAMF120035HM0MA <sup>1</sup>	641	641	641	641	422	262	187	147	104	67.0	44.7	36.9	31.6	17.4
M12V50FT	NAMF120050HM0MA <sup>1</sup>	868	868	868	868	561	351	259	208	145	92.3	60.8	49.9	42.4	22.9
M12V60FT	NAMF120060HM0MA <sup>1</sup>	1114	1114	1114	1114	694	420	301	238	171	112	76.1	61.9	52.3	27.6
M12V90FT	NAMF120090HM0FA <sup>1</sup>	1360	1360	1360	1360	990	630	454	359	259	171	114	93.4	78.9	41.6
M12V105FT	NAMF120105HM0FA <sup>1</sup>	1600	1600	1600	1600	1085	690	497	393	283	187	125	102	86.8	46.4
M12V125FT	NAMF120125HM0FA <sup>1</sup>	1321	1321	1321	1321	1321	828	601	479	348	233	164	133	111	57.8
M12V155FT	NAMF120155HM0FA <sup>1</sup>	1916	1916	1916	1916	1517	975	718	579	419	282	195	159	134	71.2
M12V180FT	NAMF120180VM0FA	1648	1648	1648	1648	1648	1102	819	646	468	308	209	174	150	85.0
M12V190FT	NAMF120190HM0FA <sup>1</sup>	2337	2337	2337	2337	1779	1190	865	698	505	332	226	188	162	91.9

#### 1.87 V<sub>pc</sub> – Discharge in W/block at 20 °C

Type	Part number	3 min	5 min	10 min	15 min	30 min	1 h	1,5 h	2 h	3 h	5 h	8 h	10 h	12 h	24 h
M6V200FT	NAMT060200HM0FA <sup>1</sup>	1320	1320	1320	1320	1006	664	502	411	294	193	130	107	91.2	48.4
M12V35FT	NAMF120035HM0MA <sup>1</sup>	679	679	679	679	444	277	198	155	109	70.5	46.9	38.7	33.0	18.1
M12V50FT	NAMF120050HM0MA <sup>1</sup>	939	939	939	939	596	371	270	214	152	96.7	63.5	52.0	44.2	23.7
M12V60FT	NAMF120060HM0MA <sup>1</sup>	1130	1130	1130	1130	740	444	318	251	180	118	79.8	64.9	54.8	28.9
M12V90FT	NAMF120090HM0FA <sup>1</sup>	1430	1430	1430	1430	1035	665	477	377	271	178	119	97.6	82.4	43.4
M12V105FT	NAMF120105HM0FA <sup>1</sup>	1670	1670	1670	1670	1144	722	519	410	295	194	130	106	90.5	48.3
M12V125FT	NAMF120125HM0FA <sup>1</sup>	1400	1400	1400	1400	1400	873	634	504	366	244	168	139	117	60.6
M12V155FT	NAMF120155HM0FA <sup>1</sup>	2200	2200	2200	2200	1634	1042	758	605	440	295	203	165	140	74.1
M12V180FT	NAMF120180VM0FA	2980	2980	2980	2549	1765	1164	875	688	496	324	219	182	156	87.9
M12V190FT	NAMF120190HM0FA <sup>1</sup>	2684	2684	2684	2684	1907	1257	912	744	536	350	237	196	169	95.0

<sup>1</sup> Discharge data are also valid for other containers.

## Marathon M FT

### Constant power discharge

#### 1.85 Vpc – Discharge in W/block at 20 °C

Type	Part number	3 min	5 min	10 min	15 min	30 min	1 h	1,5 h	2 h	3 h	5 h	8 h	10 h	12 h	24 h
M6V200FT	NAMT060200HM0FA <sup>1</sup>	1920	1820	1600	1420	1060	692	522	427	305	199	134	111	94.0	49.8
M12V35FT	NAMF120035HM0MA <sup>1</sup>	710	710	710	710	460	288	205	161	113	72.8	48.4	39.9	34.0	18.6
M12V50FT	NAMF120050HM0MA <sup>1</sup>	988	988	988	988	620	387	276	217	155	101	66.0	53.6	45.3	23.8
M12V60FT	NAMF120060HM0MA <sup>1</sup>	1174	1174	1174	1174	786	449	324	257	185	122	82.3	66.9	56.5	29.7
M12V90FT	NAMF120090HM0FA <sup>1</sup>	2280	2080	1730	1480	1060	689	493	389	279	183	123	100	84.8	44.6
M12V105FT	NAMF120105HM0FA <sup>1</sup>	2989	2700	2090	1720	1185	743	533	422	303	199	134	109	93.0	49.6
M12V125FT	NAMF120125HM0FA <sup>1</sup>	2114	2114	2114	2114	1454	905	655	521	377	251	172	144	121	62.4
M12V155FT	NAMF120155HM0FA <sup>1</sup>	3500	3200	2700	2350	1717	1083	786	626	454	303	209	170	143	75.9
M12V180FT	NAMF120180VM0FA <sup>1</sup>	3168	3168	3168	2659	1832	1196	894	709	510	332	224	185	159	89.1
M12V190FT	NAMF120190HM0FA <sup>1</sup>	4065	3900	3275	2835	1979	1292	938	766	551	359	242	200	172	96.3

#### 1.83 Vpc – Discharge in W/block at 20 °C

Type	Part number	3 min	5 min	10 min	15 min	30 min	1 h	1,5 h	2 h	3 h	5 h	8 h	10 h	12 h	24 h
M6V200FT	NAMT060200HM0FA <sup>1</sup>	2070	1950	1700	1500	1100	712	535	437	311	203	138	112	95.3	50.6
M12V35FT	NAMF120035HM0MA <sup>1</sup>	730	730	730	730	468	292	208	163	115	73.8	49.1	40.4	34.5	18.9
M12V50FT	NAMF120050HM0MA <sup>1</sup>	1014	1014	1014	1014	633	396	281	221	157	102	67.2	54.5	45.8	23.8
M12V60FT	NAMF120060HM0MA <sup>1</sup>	1217	1217	1217	1217	804	458	330	261	188	124	83.6	67.9	57.3	30.1
M12V90FT	NAMF120090HM0FA <sup>1</sup>	2430	2200	1820	1550	1090	700	501	395	282	185	124	101	85.8	45.2
M12V105FT	NAMF120105HM0FA <sup>1</sup>	3121	2810	2200	1800	1216	760	545	431	309	203	137	112	95.0	50.3
M12V125FT	NAMF120125HM0FA <sup>1</sup>	2178	2178	2178	2178	1489	924	669	532	385	256	176	148	124	63.4
M12V155FT	NAMF120155HM0FA <sup>1</sup>	3850	3400	2850	2450	1770	1112	805	641	464	309	213	173	146	77.3
M12V180FT	NAMF120180VM0FA <sup>1</sup>	3344	3344	3344	2763	1889	1224	917	726	520	338	227	188	161	90.2
M12V190FT	NAMF120190HM0FA <sup>1</sup>	4380	4100	3460	2960	2040	1321	965	784	562	365	246	203	174	97.5

#### 1.80 Vpc – Discharge in W/block at 20 °C

Type	Part number	3 min	5 min	10 min	15 min	30 min	1 h	1,5 h	2 h	3 h	5 h	8 h	10 h	12 h	24 h
M6V200FT	NAMT060200HM0FA <sup>1</sup>	2327	2160	1840	1605	1165	749	558	453	322	209	142	116	98.2	51.9
M12V35FT	NAMF120035HM0MA <sup>1</sup>	762	762	762	762	481	299	213	167	117	75.4	50.1	41.3	35.2	19.2
M12V50FT	NAMF120050HM0MA <sup>1</sup>	1055	1055	1055	1055	653	407	289	227	161	104	68.8	55.5	46.6	23.9
M12V60FT	NAMF120060HM0MA <sup>1</sup>	1287	1287	1287	1287	831	472	339	268	192	127	85.5	69.5	58.6	30.7
M12V90FT	NAMF120090HM0FA <sup>1</sup>	2600	2330	1890	1600	1110	717	512	403	288	188	127	103	87.3	46.0
M12V105FT	NAMF120105HM0FA <sup>1</sup>	3313	2950	2250	1840	1249	780	558	441	316	207	140	114	96.9	51.2
M12V125FT	NAMF120125HM0FA <sup>1</sup>	2255	2255	2255	2255	1532	949	686	545	394	262	179	151	127	64.8
M12V155FT	NAMF120155HM0FA <sup>1</sup>	4100	3650	3000	2530	1820	1148	829	658	475	316	217	177	149	78.8
M12V180FT	NAMF120180VM0FA <sup>1</sup>	3589	3589	3589	2905	1958	1254	938	743	531	344	231	191	163	90.8
M12V190FT	NAMF120190HM0FA <sup>1</sup>	4730	4350	3630	3088	2093	1345	980	797	571	370	247	205	176	98.1

#### 1.78 Vpc – Discharge in W/block at 20 °C

Type	Part number	3 min	5 min	10 min	15 min	30 min	1 h	1,5 h	2 h	3 h	5 h	8 h	10 h	12 h	24 h
M6V200FT	NAMT060200HM0FA <sup>1</sup>	2460	2270	1910	1660	1193	760	565	457	325	211	143	117	98.9	52.2
M12V35FT	NAMF120035HM0MA <sup>1</sup>	773	773	773	773	485	301	214	168	118	76.0	50.5	41.6	35.5	19.4
M12V50FT	NAMF120050HM0MA <sup>1</sup>	1059	1059	1059	1059	658	409	290	228	162	105	69.1	55.7	46.8	24.0
M12V60FT	NAMF120060HM0MA <sup>1</sup>	1315	1315	1315	1315	840	476	341	270	193	127	86.0	69.9	58.9	30.9
M12V90FT	NAMF120090HM0FA <sup>1</sup>	2910	2570	2000	1650	1130	721	514	404	290	189	128	104	87.9	46.3
M12V105FT	NAMF120105HM0FA <sup>1</sup>	3456	3070	2350	1900	1272	789	565	446	319	210	142	115	98.0	51.7
M12V125FT	NAMF120125HM0FA <sup>1</sup>	2291	2291	2291	2291	1552	960	694	551	398	264	181	153	128	65.6
M12V155FT	NAMF120155HM0FA <sup>1</sup>	4350	3900	3120	2600	1860	1166	841	668	482	320	220	179	151	79.6
M12V180FT	NAMF120180VM0FA <sup>1</sup>	3692	3692	3692	2988	1994	1269	945	751	536	347	232	192	164	90.8
M12V190FT	NAMF120190HM0FA <sup>1</sup>	5046	4641	3720	3137	2114	1355	990	803	574	371	249	206	176	98.1

<sup>1</sup> Discharge data are also valid for other containers.

## Marathon M FT

### Constant power discharge

#### 1.75 Vpc – Discharge in W/block at 20 °C

Type	Part number	3 min	5 min	10 min	15 min	30 min	1 h	1.5 h	2 h	3 h	5 h	8 h	10 h	12 h	24 h
M6V200FT	NAMT060200HMOFA <sup>1</sup>	2590	2385	1975	1700	1218	773	572	462	327	213	144	118	99.8	52.6
M12V35FT	NAMF120035HMOMA <sup>1</sup>	790	790	790	790	485	304	216	170	119	76.8	51.0	42.0	35.9	19.6
M12V50FT	NAMF120050HMOMA <sup>1</sup>	1088	1088	1088	1088	668	412	293	229	163	106	69.6	56.1	47.0	24.0
M12V60FT	NAMF120060HMOMA <sup>1</sup>	1358	1358	1358	1358	852	482	345	272	195	128	86.8	70.5	59.4	31.1
M12V90FT	NAMF120090HMOFA <sup>1</sup>	3200	2780	2080	1690	1150	728	516	405	290	190	129	105	88.9	46.7
M12V105FT	NAMF120105HMOFA <sup>1</sup>	3612	3200	2460	1970	1292	796	570	450	322	211	143	116	98.8	52.0
M12V125FT	NAMF120125HMOFA <sup>1</sup>	2307	2307	2307	2307	1562	966	697	553	399	266	183	155	130	66.2
M12V155FT	NAMF120155HMOFA <sup>1</sup>	4550	4070	3250	2659	1890	1171	847	673	484	322	220	180	152	80.3
M12V180FT	NAMF120180VMOFA <sup>1</sup>	4884	4884	3837	3092	2033	1290	951	758	541	349	233	193	165	91.4
M12V190FT	NAMF120190HMOFA <sup>1</sup>	5278	4900	3900	3227	2153	1371	1000	811	579	372	251	207	177	98.1

#### 1.73 Vpc – Discharge in W/block at 20 °C

Type	Part number	3 min	5 min	10 min	15 min	30 min	1 h	1.5 h	2 h	3 h	5 h	8 h	10 h	12 h	24 h
M6V200FT	NAMT060200HMOFA <sup>1</sup>	2770	2520	2040	1735	1242	782	577	465	329	214	145	118	100	52.7
M12V35FT	NAMF120035HMOMA <sup>1</sup>	794	794	794	794	487	305	217	170	120	77.0	51.2	42.2	36.0	19.7
M12V50FT	NAMF120050HMOMA <sup>1</sup>	1094	1094	1094	1094	671	413	293	230	163	106	69.8	56.2	47.1	24.0
M12V60FT	NAMF120060HMOMA <sup>1</sup>	1371	1371	1371	1371	855	483	346	273	196	128	87.0	70.6	59.6	31.2
M12V90FT	NAMF120090HMOFA <sup>1</sup>	3350	2900	2125	1720	1160	732	518	405	291	191	129	105	89.0	46.8
M12V105FT	NAMF120105HMOFA <sup>1</sup>	3800	3350	2530	2030	1304	800	572	451	323	212	144	117	99.0	52.1
M12V125FT	NAMF120125HMOFA <sup>1</sup>	2324	2324	2324	2324	1573	970	699	554	400	267	183	155	130	66.5
M12V155FT	NAMF120155HMOFA <sup>1</sup>	4850	4300	3330	2720	1910	1177	853	679	488	324	221	180	152	80.7
M12V180FT	NAMF120180VMOFA <sup>1</sup>	5049	5049	3925	3148	2051	1292	954	761	543	350	234	193	165	91.4
M12V190FT	NAMF120190HMOFA <sup>1</sup>	5626	5275	4144	3340	2195	1393	1018	819	584	377	252	208	178	98.8

#### 1.70 Vpc – Discharge in W/block at 20 °C

Type	Part number	3 min	5 min	10 min	15 min	30 min	1 h	1.5 h	2 h	3 h	5 h	8 h	10 h	12 h	24 h
M6V200FT	NAMT060200HMOFA <sup>1</sup>	2960	2650	2100	1770	1255	790	581	467	330	214	145	118	100	52.9
M12V35FT	NAMF120035HMOMA <sup>1</sup>	801	801	801	801	490	308	219	172	120	77.5	51.4	42.3	36.1	19.7
M12V50FT	NAMF120050HMOMA <sup>1</sup>	1104	1104	1104	1104	674	414	294	231	164	106	70.1	56.4	47.3	24.1
M12V60FT	NAMF120060HMOMA <sup>1</sup>	1391	1391	1391	1391	858	485	348	274	196	129	87.3	70.9	59.8	31.3
M12V90FT	NAMF120090HMOFA <sup>1</sup>	3500	3000	2170	1750	1170	735	519	406	292	192	129	105	89.1	46.9
M12V105FT	NAMF120105HMOFA <sup>1</sup>	4000	3551	2650	2100	1312	803	575	453	324	213	144	117	99.3	52.2
M12V125FT	NAMF120125HMOFA <sup>1</sup>	2340	2340	2340	2340	1582	974	701	555	400	268	185	155	130	66.9
M12V155FT	NAMF120155HMOFA <sup>1</sup>	5200	4600	3380	2770	1935	1183	857	682	491	326	222	180	153	80.9
M12V180FT	NAMF120180VMOFA <sup>1</sup>	5274	5274	4123	3213	2068	1294	962	765	545	351	235	193	166	91.4
M12V190FT	NAMF120190HMOFA <sup>1</sup>	5900	5453	4239	3400	2215	1395	1020	822	586	378	252	208	178	98.8

#### 1.67 Vpc – Discharge in W/block at 20 °C

Type	Part number	3 min	5 min	10 min	15 min	30 min	1 h	1.5 h	2 h	3 h	5 h	8 h	10 h	12 h	24 h
M6V200FT	NAMT060200HMOFA <sup>1</sup>	3100	2750	2150	1800	1270	799	585	469	331	215	145	119	100	53.1
M12V35FT	NAMF120035HMOMA <sup>1</sup>	808	808	808	808	493	309	220	173	121	77.9	51.7	42.5	36.3	19.8
M12V50FT	NAMF120050HMOMA <sup>1</sup>	1113	1113	1113	1113	678	416	295	232	165	107	70.5	56.7	47.4	24.1
M12V60FT	NAMF120060HMOMA <sup>1</sup>	1412	1412	1412	1412	862	487	349	275	197	130	87.6	71.1	60.0	31.3
M12V90FT	NAMF120090HMOFA <sup>1</sup>	3640	3080	2200	1780	1180	737	521	407	292	192	129	105	89.3	47.0
M12V105FT	NAMF120105HMOFA <sup>1</sup>	4250	3670	2730	2140	1321	806	577	455	325	213	145	117	99.6	52.4
M12V125FT	NAMF120125HMOFA <sup>1</sup>	2357	2357	2357	2357	1591	978	703	557	401	268	185	156	131	67.3
M12V155FT	NAMF120155HMOFA <sup>1</sup>	5300	4680	3420	2830	1950	1189	862	686	494	327	222	181	153	81.2
M12V180FT	NAMF120180VMOFA <sup>1</sup>	5498	5498	4177	3258	2078	1298	964	766	546	353	235	194	166	92.0
M12V190FT	NAMF120190HMOFA <sup>1</sup>	6148	5696	4367	3470	2234	1398	1025	826	588	380	254	209	179	98.8

<sup>1</sup> Discharge data are also valid for other containers.

## Marathon M FT

### Constant power discharge

#### 1.65 Vpc – Discharge in W/block at 20 °C

Type	Part number	3 min	5 min	10 min	15 min	30 min	1 h	1,5 h	2 h	3 h	5 h	8 h	10 h	12 h	24 h
M6V200FT	NAMT060200HM0FA <sup>1</sup>	3200	2850	2200	1835	1285	805	588	471	332	216	146	119	101	53.2
M12V35FT	NAMF120035HMOMA <sup>1</sup>	812	812	812	812	495	309	221	174	122	78.1	51.8	42.6	36.3	19.8
M12V50FT	NAMF120050HMOMA <sup>1</sup>	1120	1120	1120	1120	680	416	296	232	165	107	70.7	56.8	47.5	24.1
M12V60FT	NAMF120060HMOMA <sup>1</sup>	1424	1424	1424	1424	865	489	350	276	197	130	87.8	71.3	60.1	31.4
M12V90FT	NAMF120090HM0FA <sup>1</sup>	3800	3190	2250	1800	1190	739	522	408	293	193	130	105	89.3	47.0
M12V105FT	NAMF120105HM0FA <sup>1</sup>	4505	3800	2770	2160	1326	809	579	456	326	214	145	118	99.8	52.5
M12V125FT	NAMF120125HM0FA <sup>1</sup>	2373	2373	2373	2373	1599	981	705	557	403	269	186	157	131	67.6
M12V155FT	NAMF120155HM0FA <sup>1</sup>	5500	4800	3470	2850	1960	1196	865	688	496	328	223	182	153	81.3
M12V180FT	NAMF120180VM0FA	5575	5575	4206	3280	2080	1300	965	767	547	353	235	195	166	92.0
M12V190FT	NAMF120190HM0FA <sup>1</sup>	6380	5938	4480	3518	2244	1402	1030	828	590	381	254	210	179	99.4

#### 1.60 Vpc – Discharge in W/block at 20 °C

Type	Part number	3 min	5 min	10 min	15 min	30 min	1 h	1,5 h	2 h	3 h	5 h	8 h	10 h	12 h	24 h
M6V200FT	NAMT060200HM0FA <sup>1</sup>	3360	2950	2250	1850	1295	805	588	471	332	216	146	119	101	53.2
M12V35FT	NAMF120035HMOMA <sup>1</sup>	812	812	812	812	495	309	221	174	122	78.1	51.8	42.6	36.3	19.8
M12V50FT	NAMF120050HMOMA <sup>1</sup>	1120	1120	1120	1120	680	416	296	232	165	107	70.7	56.8	47.5	24.1
M12V60FT	NAMF120060HMOMA <sup>1</sup>	1424	1424	1424	1424	865	489	350	276	197	130	87.8	71.3	60.1	31.4
M12V90FT	NAMF120090HM0FA <sup>1</sup>	3900	3290	2300	1820	1200	739	522	408	293	193	130	105	89.3	47.0
M12V105FT	NAMF120105HM0FA <sup>1</sup>	4900	3960	2795	2180	1326	809	579	456	326	214	145	118	99.8	52.5
M12V125FT	NAMF120125HM0FA <sup>1</sup>	2373	2373	2373	2373	1599	981	705	557	403	269	186	157	131	67.6
M12V155FT	NAMF120155HM0FA <sup>1</sup>	5750	5000	3500	2870	1970	1196	865	688	496	328	223	182	153	81.3
M12V180FT	NAMF120180VM0FA	5757	5757	4258	3321	2081	1304	969	770	549	354	237	195	167	92.0
M12V190FT	NAMF120190HM0FA <sup>1</sup>	6600	6200	4600	3650	2300	1410	1050	829	591	385	254	211	179	99.4



<sup>1</sup> Discharge data are also valid for other containers.

## Battery Service – Energy Solutions

Keeping your business on the move

### GNB® is the Expert

Who could do this job better than the professionals of a company with more than 100 years of experience in battery development, production and application?

Leave the responsibility for the maintenance of your batteries and chargers to the professionals: a GNB service contract provides you with exceptional economic advantages through time savings, cost savings and safety!



### Installation of Batteries and Systems for Network Power

- > Development of complete turnkey solutions from the design concept to installation and commissioning.
- > Installation according to legal and safety regulations including CE certification by approved installation technicians.
- > Training and certification of external installation technicians according to CE regulations.

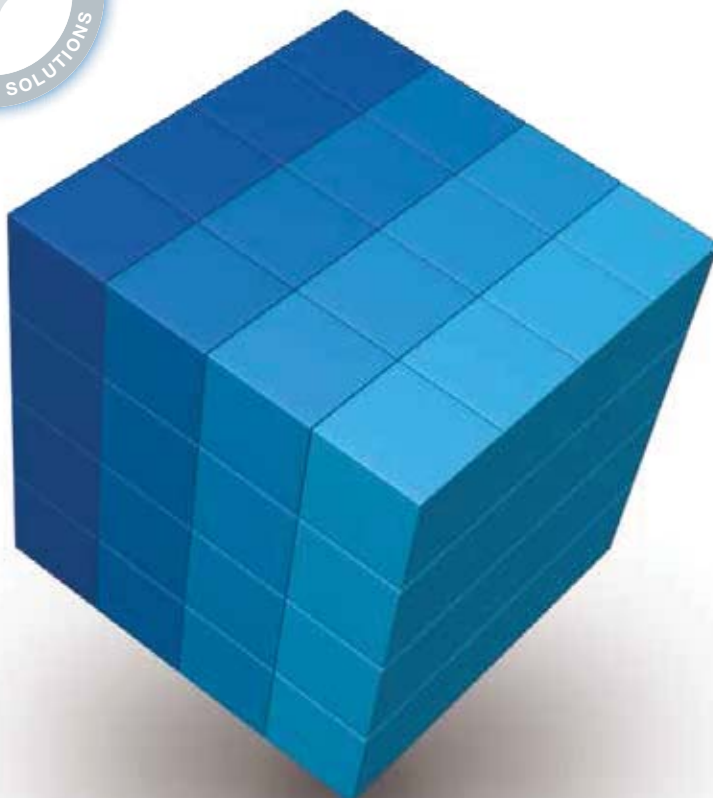

- ✦ Inspection Contract
- ✦ Maintenance Contract
- ✦ Lifetime Warranty Contract
- ✦ Full Service Contract



»GNB Service – individualized, professional and all over Europe!«



