



Power Availability

# GXT2 10000T230

User Manual



**10kVA**  
**230V**  
**50/60Hz**

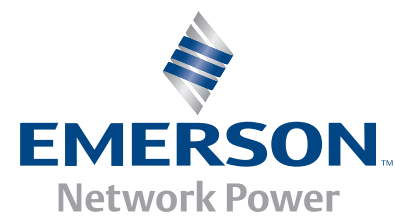



# ***Table Of Contents***

<b>Important Safety Instructions</b> .....	1
<b>1 Introduction and System Description</b> .....	5
1.1 Device Overview .....	6
<b>2 Unpacking the UPS and Site Preparation</b> .....	7
2.1 Inspection .....	7
2.2 Required Setup Equipment .....	7
2.3 Unpacking .....	7
2.4 Storage .....	8
2.5 Handling .....	8
2.6 Environmental Conditions .....	8
2.7 Access required .....	8
2.8 Floor/Rack Loading .....	8
2.9 Inventory List .....	9
2.10 Clearance .....	9
2.11 Repacking the UPS .....	9
<b>3 Installation</b> .....	11
3.1 Electrical preparations .....	11
3.2 Installation Data .....	12
3.3 Current Table and Suggested Cable Sizes .....	16
3.4 Neutral Connection .....	17
3.5 External Protection and Isolating Devices .....	17
3.6 Installation of Differential Protection Devices .....	18
3.7 External Electrical Connections .....	18
3.8 Connecting Mains and Load .....	19
3.9 Terminal Blocks for UPS .....	19
3.10 Connecting Power Cables .....	19
3.11 External Tower Batteries .....	20
3.12 Connecting an External Battery Extension .....	20
3.13 Battery Precautions .....	21
3.14 Configuration Program .....	22
3.14.1 GXT2-10000T230 Configuration Program Features .....	22
3.14.2 What You Will Need .....	22
<b>4 Operation</b> .....	23
4.1 Normal Operating .....	23
4.1.1 Block diagram .....	23
4.2 Control Panel .....	24
4.2.1 Controls and Messages .....	24
4.2.2 Setup Parameter 53 of LCD Main Menu .....	29
4.2.3 Warning Indicators .....	29
4.2.4 Fault Indicators .....	29
4.3 Pre-startup .....	31
4.4 UPS Startup Procedure - Single Block .....	32
4.5 UPS Shutdown Procedure - All Ratings .....	33
4.6 Maintenance Bypass Procedure .....	33
4.7 Return from Maintenance Bypass Procedure .....	34
4.8 Maintenance Switch, Off position .....	34
4.9 Functional Test .....	35
4.10 Emergency Switch Device .....	35

4.11 Remote Emergency Power Off .....	36
4.12 Self-Tests.....	37
4.12.1 Lamp Test .....	37
4.12.2 Battery Test .....	37
<b>5 Maintenance</b> .....	<b>39</b>
5.1 Testing, replacement and disposal of batteries.....	39
5.1.1 Easy Battery Replacement .....	39
5.2 Storage.....	40
5.3 Cleaning .....	40
<b>6 Interfaces</b> .....	<b>41</b>
6.1 Communications Interface Port.....	41
6.2 Relay Contacts.....	41
6.2.1 Pin 11 - Remote Shutdown on Battery .....	43
6.2.2 Pin 16 - Any Mode Shutdown .....	43
6.3 UPS Intelligent Communications.....	44
<b>7 Troubleshooting</b> .....	<b>45</b>
<b>8 Options</b> .....	<b>47</b>
8.1 External Battery Cabinets.....	47
8.2 Additional Battery Charger .....	47
8.3 Optional Interfaces .....	48
8.4 Battery Run Times .....	48
<b>9 Product Warranty Registration</b> .....	<b>49</b>

# Important Safety Instructions



## WARNING

Opening or removing the cover may expose you to lethal voltages within this unit even when it is apparently not operating and the input wiring is disconnected from the electrical source. Observe all cautions and warnings in this manual. Failure to do so may result in serious injury or death. Refer all UPS and battery service to qualified service personnel. Do not attempt to service this product yourself. Never work alone.

## KEEP THESE INSTRUCTIONS IN A SAFE PLACE

This manual contains important safety instructions that must be followed when installing, operating and maintaining the GXT2-10000T230 uninterruptible power system (UPS).

Read all safety, installation and operating instructions before installing or operating the UPS. Adhere to all warnings on the unit and in this manual. Follow all operating and user instructions.

The GXT2-10000T230 is not intended for use with life support or other designated critical devices. The UPS is designed for data processing equipment. If uncertain the intended use for this UPS, consult your dealer or Liebert representative.

This device serves as an uninterruptible power supply for connected loads. Maximum load must not exceed that shown on the UPS rating label. The device is in compliance with all relevant safety regulations concerning information technology equipment, including electronic machines for use in an office environment.

Depending on the type and rating of UPS device, certain configurations of battery extensions may be connected. These battery extensions may be connected only to the compatible basic UPS unit...



## WARNING

Liebert considers the safety of personnel to be of paramount importance. For this reason it is essential that procedures relating to safety be studied before commencing work and properly adhered to thereafter.

- The user or operator may intervene in the operation of the UPS provided that the instructions laid out in “Notes Regarding the EU Declaration of Conformity” on page 3 are strictly adhered to.
- The installation of the UPS, described in “Installation” on page 11, may only be carried out by qualified technical personnel.
- Even when all switches and interrupters are open, hazardous voltages are present within the UPS; any operation that requires protective panels to be opened or removed may be carried out by Liebert authorized technical personnel only.



### CAUTION

Carefully read the following safety notices! Failure to observe the instructions may endanger your life, your health, the reliability of your device and the security of your data.

- Transport the unit only in suitable packaging (protected against jolts and shocks).
- If the equipment is moved from a cold environment to the operating room, condensation may occur. Before you switch on the equipment, it must be absolutely dry. An acclimatization period of at least two hours is required.
- The equipment must be installed in accordance with the environmental conditions specified in “Environmental Conditions” on page 8 and in “Environmental Data” on page 12.
- The UPS should not be supplied with > IT (Impedance a Terre) electrical power systems (IEC 364-ELECTRICAL INSTALLATION OF BUILDINGS).
- Even with all switches in the “OFF” position(see “Control Panel” on page 24) the UPS is not isolated from the mains. To isolate completely from the mains, the power cables must be disconnected.
- In case of interruption of the mains voltage, the integrated battery maintains the power supply to the user equipment.
- Lay all cables so that nobody can stand on them or trip over them. When connecting the UPS to the power supply, follow the instructions in “Unpacking the UPS and Site Preparation” on page 7.
- Make sure that no objects (e.g., pins, necklaces, paper clips, etc.) get inside the device.
- In emergencies (e.g., damaged case, controls or power cables, penetration of liquids or foreign matter), switch off the device and contact the appropriate customer service representative.
- Do not connect equipment that will overload the UPS (e.g., laser printers or vacuum cleaners) or demand DC-current (e.g., half-wave rectifiers).
- When cleaning the unit, follow the instructions in “Maintenance” on page 39.
- The sum of the leakage currents (protective conductor current) of the UPS and the connected devices exceeds 3.5 mA for all ratings of the UPS. Earth connection is essential before connecting supply.
- Data transmission lines should not be connected or disconnected during a thunderstorm.
- Remote Emergency Power Off (REPO) input is located on the rear of the unit (see “Emergency Switch Device” on page 35 and “Terminal Blocks for UPS” on page 19). When this connection is open, the logic circuit will immediately shut down the UPS output.
- An Emergency Switching Device (E.S.D.) must be fitted downstream of the UPS for the wiring installation safety to comply with the European Harmonized Document HD384-4-46 S1.



- Maintenance bypass switch is for the use of service personnel only. It is located under the rear cover. Open the safety cover to operate the maintenance bypass switch.
- The Tower UPS may be connected either to 3-phase mains or single-phase mains. Therefore the right input terminals have to be connected (see “Connecting Mains and Load” on page 19). The UPS autosensing mode ensures that it adapts to the connected mains supply.

Further safety notes for GXT2-10000T230

- Do **not** connect more than four GXT2-240TBATTCE battery extensions to the GXT2-10000T230. This also applies when the additional battery charger is connected.
- The vents for air intake and outlet at the front and rear side must not be obstructed.
- The sum of the leakage currents (protective conductor current) of the UPS and the connected devices exceeds 3.5 mA. Earth connection of the unit is essential before connecting supply.



#### **CAUTION**

The supply to the load may be interrupted by opening all the switches or by turning the Maintenance Switch on the rear of the UPS to the Off position.

DO NOT USE WATER to extinguish any fires that may occur in the area where the UPS is installed.

### **Leakage currents**



#### **CAUTION**

Connect the protection earth (PE) safety conductor before connecting any other cables.

### **Radio Interference**

**The GXT2-10000T230 is a Radio Interference Class A Product.**

The UPS device may cause radio interference. Do not place it near devices that are particularly susceptible to electromagnetic interference (e.g., transmitters, receivers, radar, metal detectors and antitheft devices).



#### **WARNING**

This is a product for restricted sales distribution to informed partners. Installation restrictions or additional measures may be needed to prevent radio interference.

### **Notes Regarding the EU Declaration of Conformity**

The GXT2-10000T230 conforms to the following European directives:

**73/23/EEC**

Directive of the council for adaptation of the legal regulations of the member states regarding electrical equipment for use within specific voltage limits, modified by directive 93/68/EEC.

**89/336/EEC**

Directive of the council for adaptation of the legal regulations of the member states regarding electromagnetic compatibility, modified by directive 91/263/EEC.

Conformity is established through compliance with the following standards:

EN 62040-1-1

EN 62040-2

Additional information regarding adherence to these directives is included in the appendices NSR and EMC of the EU Declaration of Conformity.

If required, the EU Declaration of Conformity may be requested from Liebert.

# 1 Introduction and System Description

Congratulations on your purchase of the Liebert UPStation GXT2-10000T230. This system provides conditioned power to microcomputers and other sensitive electronic equipment.

Upon generation, AC power is clean and stable. However, during transmission and distribution it is subject to voltage sags, spikes and complete power failure that may interrupt computer operations, cause data loss and damage equipment. The UPStation GXT2-10000T230 protects equipment from these disturbances.

The UPStation GXT2-10000T230 is a compact, on-line UPS. An on-line UPS continuously conditions and regulates its output voltage whether utility power is present or not. It supplies connected equipment with clean sinewave power. Sensitive electronic equipment operates best from sinewave power.

For ease of use, the UPStation GXT2-10000T230 features an LCD display for comprehensive user indications and programmable controls. It also provides self-diagnostic tests.

The UPStation GXT2-10000T230 has an interface port for communication between the UPS and a network server or other computer system. This port provides detailed operating information including voltages, currents and alarm status to the host system when used in conjunction with Liebert's MultiLink™ software.



## CAUTION

This UPS may only be operated by qualified personnel.

Figure 1-1 UPStation GXT2-10000T230 control panel

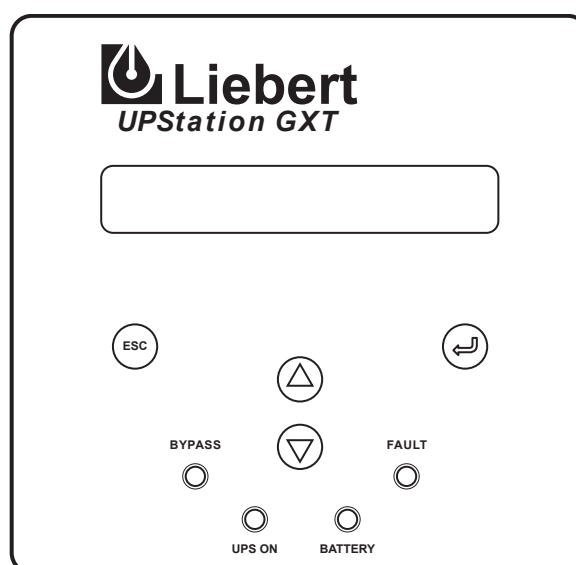

## 1.1 Device Overview

The GXT2-10000T230 is available at various nominal power ratings.

The following table provides an overview of the various versions of the device:

**Table 1-1 Overview of UPS devices and batteries**

Type	Model #	Nominal power
UPS with integrated battery	GXT2-10000T230	10000 VA / 7000 W
Battery cabinet	GXT2-240TBATTCE	240 VDC

**Figure 1-2 GXT2-10000T230 front and rear views**

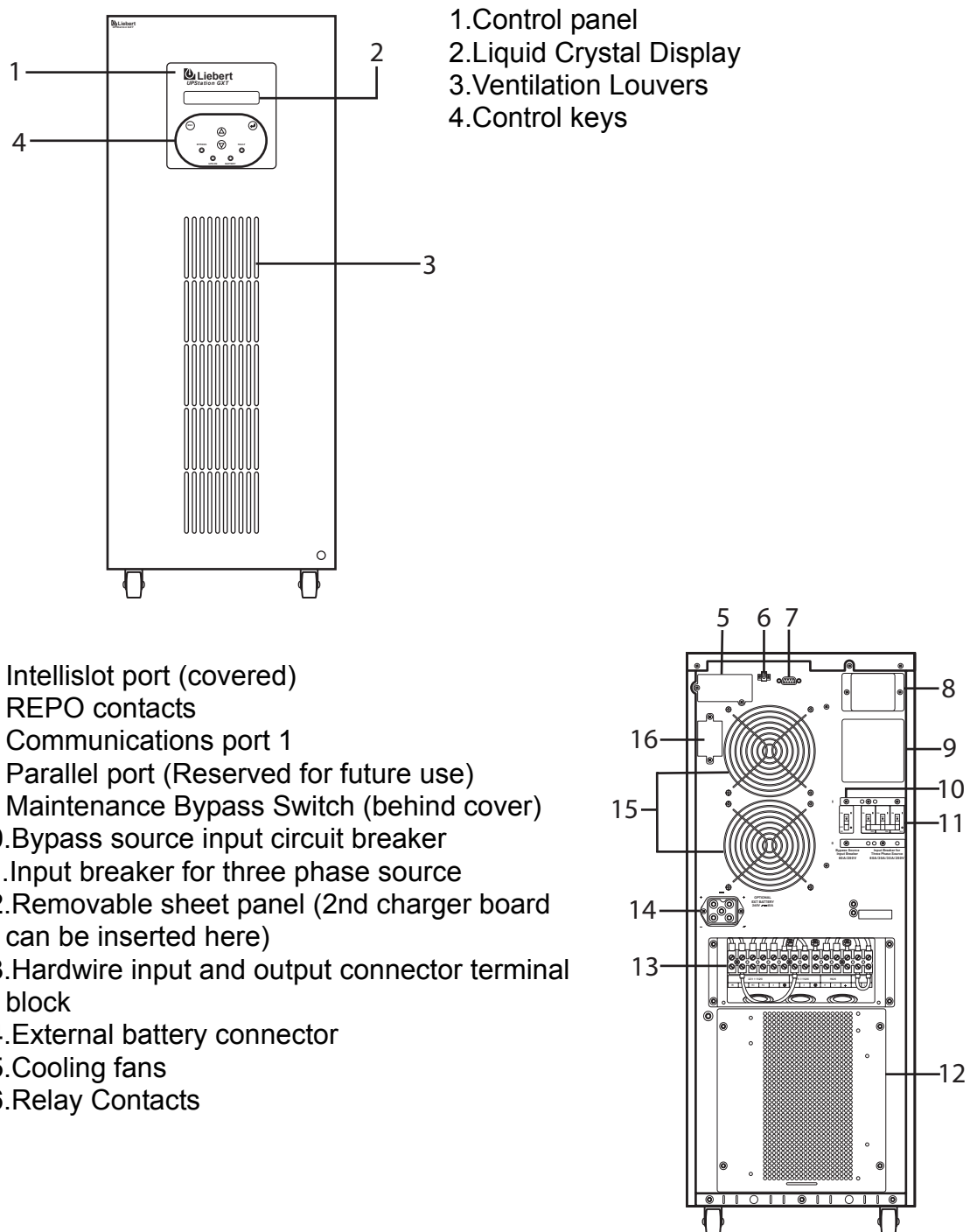

## 2 Unpacking the UPS and Site Preparation

### 2.1 Inspection

Upon receiving your GXT2-10000T230, examine the packaging for any signs of mishandling or damage. While removing the packaging materials, inspect the UPS for damage. If any damage is noted, notify your local Liebert representative and carrier. Any damage or missing parts must be reported to the supplier within eight days of delivery.

### 2.2 Required Setup Equipment

The following tools are required to set up your UPS:

- pallet jack
- utility knife or scissors
- star head screwdriver

### 2.3 Unpacking

Take care when removing the packaging to avoid damaging the UPS. Check all packaging to ensure that no items are accidentally discarded. Remove the packaging in the sequence shown below.

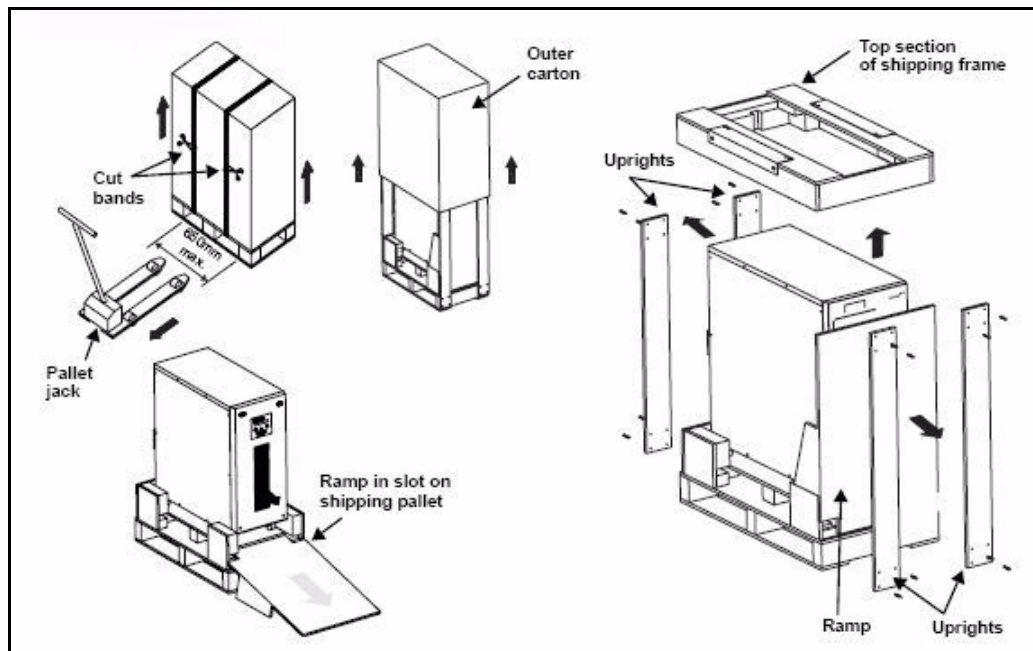

Figure 2-1 Unpacking

## 2.4 Storage

If the UPS will not be installed immediately, store the unit indoors in a clean and dry area. Protect all the equipment, including its batteries, from extreme temperature, high humidity, spills and other damaging conditions. Refer to the table below for permissible storage environmental conditions.

**Table 2-1 Storage conditions**

<b>Temperature limits Batteries ONLY</b>	0°C to +40°C (32-104°F)
<b>Temperature limits UPS without batteries</b>	-25°C to +55°C (-13°F to +131°F)
<b>Relative humidity</b>	from 0% to 90%, NON- CONDENSING

## 2.5 Handling

The equipment must be kept upright at all times and handled with care. It may be damaged if dropped or subjected to severe impact.

## 2.6 Environmental Conditions

The GXT2-10000T230 must be installed vertically, on a level and even surface and in an area protected from extreme temperatures, water, humidity and the presence of conductive powder or dust (see “Environmental Data” on page 12). Do not stack units; do not place any objects on top of a unit.

- The functional temperature range of the UPS is 0°C to 40°C (32-104°F)
- The ideal ambient temperature range is 15°C to 25°C (59-77°F)
- The battery life is defined at 20°C. Each increment of 10°C above 25°C (increment of 18°F above 77°F) reduces the expected life by 50%.

## 2.7 Access required

The area must have sufficient space for installation procedures and for routine maintenance. Access doors must be sufficiently large to permit passage of the UPS.

## 2.8 Floor/Rack Loading

Ensure that the floor where the UPS/batteries will be installed will support the unit’s weight (see Table 3-2 for the unit’s weight).

## ***2.9 Inventory List***

- The GXT2-10000T230 comes with the following:
  - one jumper for common feeding (connect mains and reserve)
  - user manual
  - multi-link CD
  - Configuration program CD
  - RS232 cable
  - Four rubber bumpers to be used if adding a GXT2-240TVBATT next to the UPS.

## ***2.10 Clearance***

The UPS is fitted with wheels for ease of movement over short distances. You must leave 300 centimeters around the side and rear of the unit to allow a flow of air and to provide access for any routine maintenance that may involve removal of the panels.

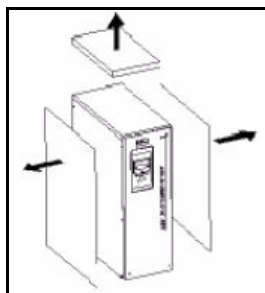

**Figure 2-2** Clearance

## ***2.11 Repacking the UPS***

To repack the UPS, proceed as follows:

1. Do not pack the equipment until at least six hours have elapsed since the last recharge.
2. Make sure to re-use the original packing material to ship the UPS.



## 3 Installation

### ***3.1 Electrical preparations***

Before you begin installation, the input source must be isolated and secured to prevent reconnection during installation. The input circuit breaker on the rear of the UPS must be in the Off position.



#### **Warning**

- Installation may be carried out only by qualified technicians, conforming to applicable safety standards.
- Electric shock hazard: Even when the unit is disconnected from the mains, hazardous voltage may still be supplied by the battery. Both poles should be disconnected before carrying out maintenance work inside the UPS.

For electrical installation, the nominal current rating of the source must be observed. The UPS is not suitable for connection to 16A subdistribution systems.

### 3.2 Installation Data

Table 3-1 Environmental Data

<b>Ambient Temperature</b>	0°C to +40°C (32-104°F)
<b>Relative Humidity (w/o Condensing at 20oC)</b>	90%
<b>Max. Altitude (w/o derating)</b>	1000 m a.s.l.
<b>Cable inlet</b>	bottom of rear side
<b>Air inlet</b>	at the front and right sides
<b>Air outlet</b>	at the rear

Table 3-2 Technical Data

Specification	Value
Rectifier	GXT2-10000T230
Nominal input voltage (VAC)	<b>230VAC Single Phase (L, N, G)</b> 230/400 Three Phase (L1, L2, L3, N, G)
Input phases (VAC)	<b>Single phase or three phase, automatic detection</b>
Input voltage	<b>176-276V for 1X1</b> 304-478V for 3X1
Nominal frequency (Hz)	50/60 Auto selection
Frequency tolerance	Output frequency equals input frequency. When the input is nominal 50 or 60Hz $\pm$ 5%. Beyond $\pm$ 5% range, inverter free runs at nominal frequency.
<b>Maximum input power (Nominal Input Voltage, R Full Load)</b>	
Float(kVA) <sup>1</sup>	8.0
Recharge (kVA) <sup>2</sup>	8.3
Power factor (at nominal V, with R full load)	Single Phase Input: 0.97 Three Phase Input: 0.95
Input current distortion (with R full load) THDi <sup>3</sup>	Single Phase Input: < 5% Three Phase Input: < 31%
Inrush current (A) (typical)	60A
<b>Battery charger</b>	
Battery nominal voltage (V DC)	240
Battery charger input voltage range (V AC)	100-276
Output voltage (V)	Multi stage charging method.

**Table 3-2 Technical Data**

Charging time to 90% capacity in inverter mode (hr.)	5
Charger output current ( $A_{DC\text{aver}}$ ) (Amps)	Standard: 1.2A (1 Charger Board with Internal Batteries) Option: 4.0A (internal option)
<b>Inverter</b>	
Nominal power rating @ 40°C (kVA)	10
Nominal active power rating (kW)	7
Power factor	0.7
Overload <ul style="list-style-type: none"> <li>• for 1 minute (%)</li> <li>• for 10 seconds (%)</li> <li>• for approximately 2 secs (RCD load) then transfer to bypass and and an audible alarm</li> </ul>	105 - 125% 126 - 150% 150 - 300 (± 50)%
Short circuit current for 5 cycles (typical)	160 A peak
Output voltage rating (Vac)	220, 230, 240
Output frequency (Hz)	50/60, auto selection
Voltage regulation over input voltage and battery voltage range with load between 0% and 100% of rating	± 2%
Output frequency stability with mains synchronism (%)	± 5%
Stability with internal quartz oscillator (%)	< 0.05%
Frequency Variation Rate (Hz/sec)	< 1
Output Voltage Distortion THD-V (%)	Full Resistive Load < 3% Full RCD Load < 8%
Load peak factor without derating (I <sub>pk</sub> /I <sub>rms</sub> )	≤ 3
<b>Static switch</b>	
Nominal frequency (Hz)	50 / 60 auto selection
Frequency tolerance (%)	Same as Input, ± 5%
Voltage tolerance (V)	176 - 255
Out-of-phase switching time (ms) in case of inverter fault and bypass is out if tolerance	No transfer
<b>Overload</b>	
Over load > 100%	Audible alarm

**Table 3-2 Technical Data**

In-phase switching time - direct/ conditioned (ms) <sup>4</sup>	0.5
condition/direct (ms)	0.5
UPS data	
25% of load (%)	87
50% of load (%)	91
75% of load (%)	92
100% of load (%)	92
Maximum noise level at 1 meter front-side (dBA) normal mode and battery mode	≤ 50
Degree of protection	IP20
Dimensions	
Height (mm)	800
Width (mm)	300
Depth (mm)	675
Color	Black
Weight with integrated batteries (kg)	110
<b>Battery</b>	
Optimum battery temperature (°C) <sup>5</sup>	15 - 25
Power output (kW)	8.5
Recommended no. of cells	120
End of discharge (VDC)	200
Battery type	YUASA: REW 45-12 (12V / 45W / 9Ah)
Battery number	20
Discharging time (minutes)	5
Auto battery missing detection	Yes
Ext. Battery Cabinet:	1Set / 2Set
Battery type	YUASA NP7-12 12V7AH
Battery number (pcs.)	40 / 80
Height (mm)	800
Width (mm)	300
Depth (mm)	675
Color	Black
Weight with integrated batteries (kg)	162

**Table 3-2 Technical Data**

Performance EN 62040-3	
Dynamic characteristics	VFI - S S - 1 1 1
Step load response	
Load 0% to 100% to 0%	+/- 5% maximum, returns to static regulation within 200 ms.
Load 20% to 100% to 20%	+/- 3% maximum, returns to static regulation within 200 ms.
Startup Operation	
Input AC < 100VAC or greater than 280 VAC	UPS will not start
Input >176 or less than 276	UPS start enabled
Load 0% to 100% to 0%	+/- 5% maximum, returns to static regulation within 200 ms.

- <sup>1</sup> Maximum input power (normal V, R full load)  
float (kVA) = [Pout (KW)/efficiency] / input\_power\_factor  
Example for the 10kVA float (kVA) = (7,0/0,91)/0,95 = 8100VA
- <sup>2</sup> Recharge (kVA) = [(Pout (KW)/efficiency)+Pbattchargerinput]/input\_power\_factor  
Example for the 10kVA Pbattchargerinput = (2.5\*268)/efficiency=(2.5\*268)/0,9=744W  
recharge (kVA) = [(7,0 (KW)/0,91)+744]/0,95 = 8880VA
- <sup>3</sup> THDi measure method is applied to EN61000-3-2, 1995
- <sup>4</sup> In-phase switching time direct / conditioned means time line (bypass) transferring to inverter
- <sup>5</sup> The expected battery life is defined at 20°C. For every increment of 10°C, above 20°C, the expected life is halved

### 3.3 Current Table and Suggested Cable Sizes

The following table indicates the currents and recommended sizes of the connecting cables in accordance with regulations IEC-287 and DIN VDE 0298

1. PVC-insulated copper cables (@ 70°C) (158°F).
2. Air temperature surrounding the conduits should not be greater than 30°C (86°F).



**NOTE**

Should there be any variation in the conditions, it will be necessary to verify whether the cable dimensions satisfy the requirements of IEC-287 and DIN VDE 0298. In cases where the cables are so long that they cause a drop in voltage of >3%, a larger size must be used.

**Table 3-3 Connection data**

Description	Unit	UPS power rating	
	kVA	10 - 1/1	10 - 3/1
Connector size	mm <sup>2</sup>	10	10
Max input current	Arms	56	56
Input cable size (and neutral)	mm <sup>2</sup>	10	10
Max output current	Arms	56	56
Output cable size (and neutral)	mm <sup>2</sup>	10	10
Earth cable size	mm <sup>2</sup>	10	10

When the UPS is in Bypass mode, the entire output current of the UPS is passed through the phase L1 and Neutral cables. To simplify connection data, no distinction has been made between phase L1 and phases L2 and L3. The cable sizes are defined for the maximum current carried by the output cables.



**WARNING**

Particularly sensitive equipment may be susceptible to interference. To prevent this, Liebert suggests:

- Mains input, output and external battery cables to the UPS in earthed, metal conduits, or
- Use shielded cables

Routing of cables (e.g. power supplies, communication or data lines) to other equipment, should be kept separate from that of UPS cables.

### 3.4 Neutral Connection

The installation of the UPS does not affect the existing Neutral system.

The Neutral system may be affected if the UPS is operating with the Neutral switched upstream.

### 3.5 External Protection and Isolating Devices

External devices for the protection of cables and for isolating the UPS external to the UPS must be installed upstream of the equipment. Select and configure the isolating device according to the table below.

- Such devices must be either curve C automatic circuit breakers or type GL/GG fuses.
- Disconnecting devices must be provided in building installations and other locations.



**WARNING**

The following label must be displayed on all switching devices installed in the same electrical system as the UPS, even when they are located at a distance from the area.

**ENSURE THAT THE UNINTERRUPTIBLE POWER SYSTEM IS ISOLATED BEFORE WORKING ON THIS CIRCUIT.**

Table 3-4

Protection Description		Tower power rating (phases in/out)	
		10 - (1/1)	10 - (3/1)
Input	Fuse	63 Amps	63 Amps
	Breaker	63 Amps	63 Amps
Output	Fuse	63 Amps	63 Amps
	Breaker	63 Amps	63 Amps

This table indicates the protection devices (circuit breakers and fuses) that must be installed for the protection of both the cables and the equipment.



**NOTE**

If an external battery cabinet is present it should be located next to the UPS unit.

- When such an option is supplied by Liebert it comes complete with protection devices and correctly-sized cables.
- When batteries are sourced from other suppliers, you should contact Customer Support Technical Service for correct sizing of protection devices and interconnection cables.

### 3.6 Installation of Differential Protection Devices

To avoid spurious operation, differential protection devices must be:

- rated at differential current NOT LESS THAN 100mA
- a SELECTIVE type (delayed intervention)
- Type A

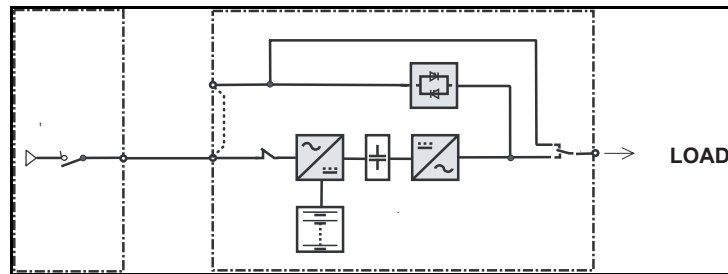

Figure 3-3 Standard configuration -- differential breaker

### 3.7 External Electrical Connections

Remove the protective panel on the rear of the UPS to access the external electrical connections (see figure below). Once the cables have been connected they must be passed through the cable clamps that will hold them in position. Connect the earth cable first.



**WARNING**

Ensure that the UPS is isolated before removing panels.

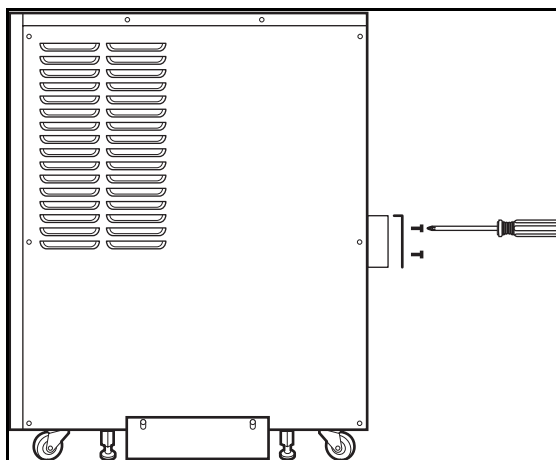

Figure 3-4 Side view



**NOTE**

Once installation has been completed, fix the UPS in position by screwing the stabilizing plates underneath the unit firmly to the floor.

### 3.8 Connecting Mains and Load

Connect the mains supply to the input terminals of the UPS. If the GXT2-1000T230 is supplied by single-phase mains, connect the live phase to input L1.

### 3.9 Terminal Blocks for UPS

The three-position maintenance switch includes the output breaker.

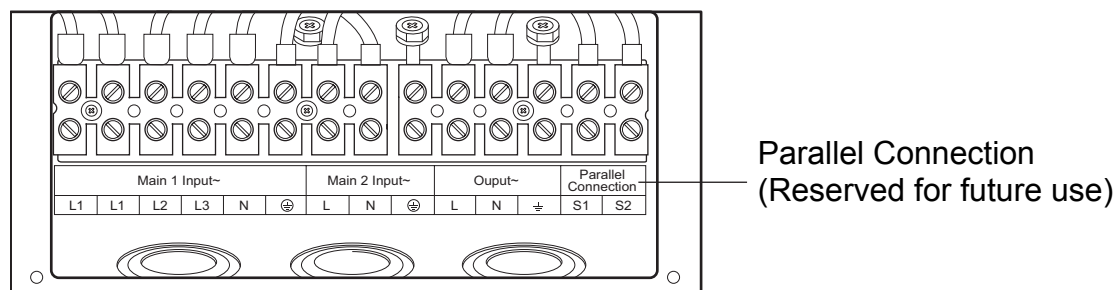

Figure 3-5 Hardwire terminals

### 3.10 Connecting Power Cables

1. Open the UPS input breaker.
2. Open the UPS output breaker.
3. Set the maintenance switch to position BPS (Bypass).
4. Remove the terminal area safety cover from the rear UPS panel.
5. Connect loads to the output terminals.
6. Connect the mains to the corresponding input terminals (see Figure 3-5).
  - If the reserve input is to be supplied separately, connect reserve line to the Mains 2 terminals.
  - If the UPS is supplied by a common mains, connect a jumper between terminal L1 (mains 1) and L (reserve/Mains 2).

### 3.11 External Tower Batteries

One or more battery cabinets may be connected to the GXT2-10000T230. A cable to connect the battery cabinet and the GXT2-10000T230 is supplied with each battery cabinet. Plug this cable into the battery cabinet and UPS battery sockets -- slotted fittings on each and ensure that the connection is properly made. If your UPS has an integrated battery, a compensating current may occur during connection.

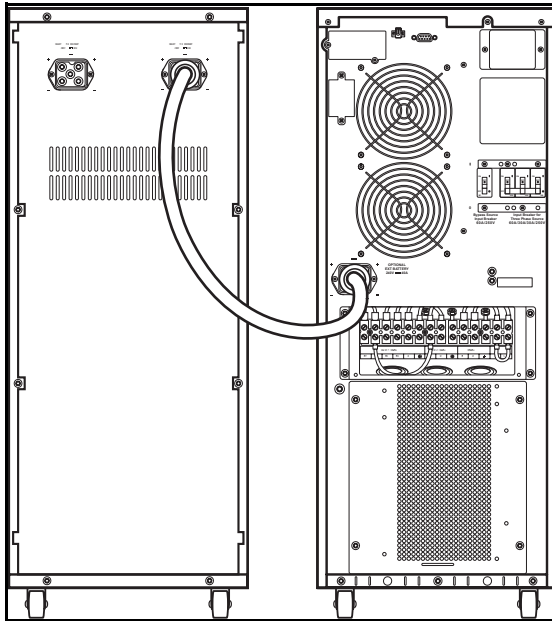

Figure 3-6 GXT2 10000T230 with External Battery Cabinet

### 3.12 Connecting an External Battery Extension



#### NOTE

External battery extensions can be replaced during normal operation of the UPS (hotswappable). However, the batteries must NOT be changed when the UPS is in the status "Battery Mode operation".

The unit checks the battery voltage (a beep is heard) once more and stays in bypass till a constant battery voltage is present.



#### CAUTION

Battery maintenance must be carried out by authorized personnel observing the necessary precautions.

### ***3.13 Battery Precautions***

- The batteries installed in the UPS and within the battery extensions may contain electrolyte. Under normal conditions, the containers are dry. A damaged may leak electrolyte which can cause skin and eye irritation. Should this happen, wash the affected area with plenty of water and seek immediate medical attention.
- Do not open or damage batteries. The released electrolyte is toxic.
- Voltage is always present on the battery contacts.
- Even when discharged, a battery has the capacity a high short circuit current which, in addition to causing damage to the battery itself and associated cables, may expose the operator to the risk of burns. The following precautions should be observed when working with batteries:
  - Remove watches, rings and other metal objects.
  - Use tools with insulated handles.
- The voltage of a single cell of a battery is not dangerous. However a number of cells or battery blocks, connected in series, can produce hazardous voltages.
- The battery cabinet must not be kept in storage or not used for periods exceeding six months (at 20°C) without being recharged (having been charged to 100% at the beginning of any such period). If this period is exceeded, it is essential that the batteries be recharged (which requires the UPS to be switched on). If these conditions are not met, the battery performance can no longer be guaranteed. We recommend recharging the batteries at least once every four months.
- Since new batteries often do not provide full capacity after the initial charge, it may be necessary to carry out a number of discharge/recharge cycles before optimum performance is reached.
- When replacing batteries, replace with the same type and number of batteries and battery packs.
- In order to protect the environment, batteries must be disposed of in accordance with local laws concerning the safe disposal of toxic and harmful waste.
- Do not dispose of batteries in a fire. The batteries may explode.

## 3.14 Configuration Program

The final step of installation may require custom configuration of your UPS using the enclosed configuration program. Some configuration settings may be changed only while the UPS is off. These should be set before the UPS is put into full-time use.

For most users operating with 230VAC, the factory default settings will be adequate.

### 3.14.1 GXT2-10000T230 Configuration Program Features

- Select one of the three L-N output voltages to match local voltage.
- Enable/disable auto-restart.
- Select frequency converter operation with a fixed output frequency of 50 or 60 Hz.
- Set the 'Low battery warning' alarm time from 2 to 30 minutes.
- Enable/disable auto-battery test.
- Set auto-battery test frequency to 7, 14, 21 or 28 days.
- Specify the number of external battery cabinets connected to the UPS to adjust the remaining run time calculations reported by the system software.

### 3.14.2 What You Will Need

In addition to the GXT2-10000T230, you will need the configuration program CD and serial cable (beige or tan, 3-wire: GND, TX, RX; straight through 2-2, 3-3, 5-5) included in the UPS accessory pack. You must be running Windows 95® or later on your computer.

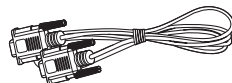

## 4 Operation

### 4.1 Normal Operating

#### 4.1.1 Block diagram

The GXT2-1000T230 consists of several main components:

- 2 mains supplies (mains and reserve)
- Rectifier/booster, inverter and charger
- Electronic bypass
- 2 input breakers
- 3 position maintenance bypass switches
- TVSS filter
- Integrated battery (expandable)
- Additional charger (optional)

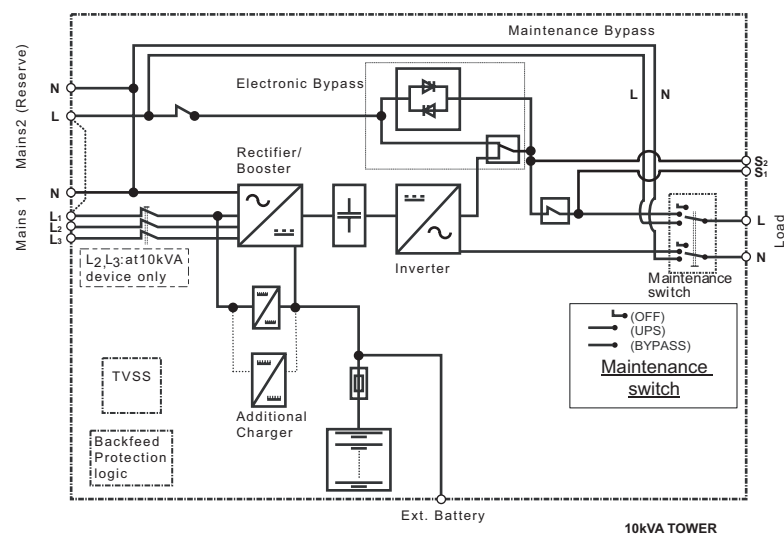
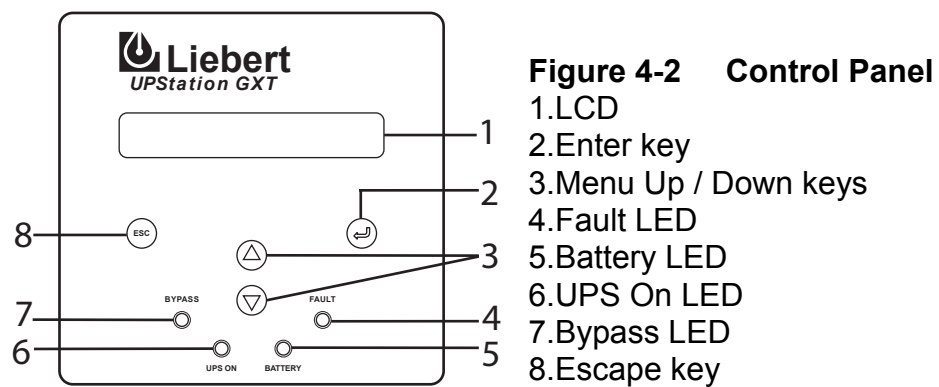

Figure 4-1 Overview of UPS tower

## 4.2 Control Panel

The display text is shown as a 10 kVA UPS.



**Figure 4-2 Control Panel**

- 1.LCD
- 2.Enter key
- 3.Menu Up / Down keys
- 4.Fault LED
- 5.Battery LED
- 6.UPS On LED
- 7.Bypass LED
- 8.Escape key

### 4.2.1 Controls and Messages

Lighted LEDs

LED Indicator	LED Color	Description
UPS ON	Green	UPS is online and operating normally
BYPASS	Amber	Load is supplied by the mains via automatic bypass
BATTERY	Amber	Load is supplied by the battery
FAULT	Red	An error has occurred within the UPS

Flashing LED:

When the BYPASS LED is flashing, the mains is out of tolerance



#### CAUTION

**Do not switch off the UPS or switch from online to bypass whilst in this status, otherwise load will no longer be supported.**

The following displays the menu structure that can be accessed through the control panel. Press the **Menu Up** or **Menu Down** buttons to scroll through each menu. Press **Enter** to choose an entry.

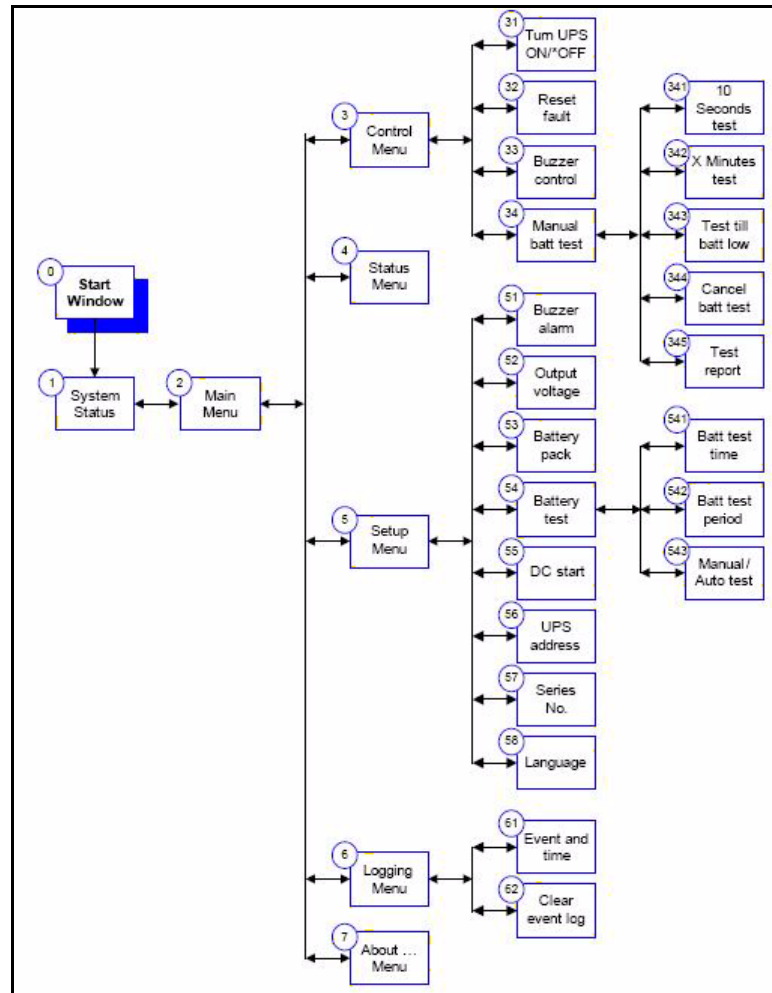

**Figure 4-3 System block, menu structure**

Menu entry	Display
0. START WINDOW	10kVA UPS Self testing please wait
	Wait about 6 sec

Menu entry	Display
1. SYSTEM STATUS	10kVA UPS UPS: "UPS mode/Warning table/Fault table" menu
	All UPS mode/Warning table of Fault table will alternate once a second

Menu entry	Display
2. MAIN MENU	Control
	Status
	Setup
	Logging
	About

Menu entry	Display			
3. CONTROL MENU	31	Turn UPS ON/OFF	Turn UPS to ONLINE	
			Turn UPS to BYPASS	
			Turn UPS to shutdown	
			Turn UPS to no output	
	32	Reset fault	Reset fault	
			No fault now	
	33	Buzzer control	Alarm ON	
			Alarm OFF	
	34	Manual batt test	341	10 Seconds test
			342	X Minutes test
			343	Test till batt low
			344	Cancel batt test
			345	Test report

Menu	Display	
4. STATUS MENU	Measure value	Unit
	L1 Input Voltage	V
	L2 Input Voltage (only 10kVA UPS)	V
	L3 Input Voltage (only 10kVA UPS)	V
	Input Freq	0.1Hz
	Output Volt	V
	Output Freq	0.1Hz
	Output Load	%
	Output current	A
	Output Watt	W
	Output VA	VA
	Battery Volt	V
	Batt capacity	%
	Back Up	Min, sec
	RunTime	day:hr:min:sec
	UPS ID	
	Plus BUS (Booster)	V
Minus BUS (Booster)	V	

Menu	Display				
5. SETUP MENU	Setting item		Setting (level 1)		Setting (level 2)
	51	Buzzer alarm	Disable/Enable		
	52	Output voltage	220/230/240 V		
	53	Battery pack	1-3 <sup>1</sup>		
	54	Battery test	541	Batt Test Time	1-99 min
			542	Batt Test Period	7-180 day
			543	Manual/ Auto test	Manual/Auto
	55	DC start	Disable/Enable		
	56	UPS address	0-31		
	57	Series no.	00000-99999		
	58	Language	English		

Display		
6. LOGIN MENU	61	Event and time <sup>2</sup>
	62	Clear event log

Display	
7. ABOUT.. MENU	Type of UPS
	Internet IP
	Software version

<sup>1</sup> For more information about setup parameter 53 or battery packs see “Setup Parameter 53 of LCD Main Menu” on page 29.

<sup>2</sup> A maximum of four fault event records will be stored.

#### 4.2.2 Setup Parameter 53 of LCD Main Menu

Paramter	Integral battery	No. of external battery cabinets	No. of 12V battery blocks in sum
1	YES	0	20
2	YES	1	60
3	YES	2	100

#### 4.2.3 Warning Indicators

If a warning indicator appears, the UPS continues to operate. The warning message alternates with UPS mode once a second.

The warning indicators are described below:

Warning	Cause	Corrective Steps
1	Batt. under volt.	N/A
2	Utility failure	N/A
3	L2 or L# failure	Check L2, L3 input fuse
4	Over temp. 65	Reduce load

#### 4.2.4 Fault Indicators

If a fault occurs, the UPS automatically switches to BYPASS mode. Only in the case of a battery disconnection fault will the original operating mode be maintained. The fault message alternates with UPS mode once a second, the red fault LED lights up on the control panel and the buzzer sounds continuously. If a fault occurs oriced as follows:

Buzzer alarm operation - The buzzer alarm can be switched on or off.

Clear Fault - Present fault condition can be reset if fault condition is cleared, either automatically or by the user.

Fault information - A maximum of 4 faults can be displayed in this window. All fault displays include:

- The nature of the event
- The time of the event

Display faults - The fault indicators are as follows:

Fault	Cause	Corrective Steps
1	DC BUS fault	Call customer service
2	Inverter fault	Call customer service
3	Over heating	Reduce load
4	Batt. over volt.	Call customer service
5	Batt. mode overload	Reduce load
6	Output overload	Reduce load
7	Output short	Call customer service
8	Fan lock fault	Call customer service
9	Batt. disconnect	Check battery connector
10	Charger failure	Call customer service
11	ESD activated	N/A
12	Parallel fault	Call customer service
13	Internal fault	Call customer service
14	Output failure	Call customer service

## 4.3 Pre-startup

Before switching on the UPS and supplying the load, ensure the following:

- The ventilation grilles are unobstructed
- The earth connection is in place
- The 'consumer' breakers are in the OFF (0) position
- The UPS rear panel breakers are in the OFF (0) position



### WARNING

**As soon as the UPS is connected to input power, the output sockets are live, even if the UPS is not yet switched on.**

Once recharging has been completed, the UPS is ready for use.



### WARNING

**Do not connect any devices that may overload the UPS or draw DC current.**



### NOTE

You may experience problems with the electrical supply if you do not follow these instructions.

## 4.4 UPS Startup Procedure - Single Block

1. Ensure all switches and circuit breakers upstream of the UPS are closed.
2. Ensure mains connections are secured at the UPS input. UPS requires twin supplies or one supply and one bridge. If the UPS is supplied from one mains only, mains connectors have to be fixed to the terminals section Mains 1. The jumper must be fixed as follows:

**From L1 - mains 1 to L - mains 2**

3. Switch both Input breakers (mains 1 and mains 2/reserve) to **ON** (I). The LCD displays '**Self testing, please wait**' (see "Controls and Messages" on page 24).
4. Wait at least 30 seconds until the output voltage has stabilized (the yellow LED is lit). The LCD displays '**BYPASS MODE**'. Then turn the Maintenance Switch to **UPS**.
5. Check setup menu 5, check and adjust if necessary parameters for language, voltage and battery pack(s) (see "System block, menu structure" on page 25' for more information). The default language is English.
6. Close any external switches connecting the load (if present).
7. Press the **Menu** button, select **Control** and press **OK**.
8. Select **Turn UPS ON/OFF** and press **OK**. The LCD will display '**Turn UPS to ONLINE**'.
9. Press **OK** to switch on the inverter.



### **WARNING**

**If the load indication is greater than 100%, then the energy demand from the connected load exceeds the power rating of the UPS. In addition to the a warning on the front panel, a beep (once a second) will sound.**

## ***4.5 UPS Shutdown Procedure - All Ratings***



### **NOTE**

Carrying out this procedure will interrupt the supply to load.

1. Press the **Menu** button, select **Control** and press **OK**.
2. Select **Turn UPS ON/OFF** and press **OK**.  
The LCD displays '**Turn UPS to Bypass**'.
3. Press **OK** to switch off the inverter.
4. Open any external switches connecting the load (if present).
5. Switch both input switches to the **Off** Position.
6. Ensure all switches and circuit breakers upstream of the UPS are open.
7. Ensure that all LEDs on the control panel are not lit.

The UPS is now shut down.

## ***4.6 Maintenance Bypass Procedure***

1. Press the **Menu** button, select **Control** and press **OK**.
2. Select **Turn UPS ON/OFF** and press **OK**.  
The LCD displays '**Turn UPS to BYPASS**'.
3. Press **OK** to switch off the inverter.
4. Remove the safety cover from the Maintenance switch and switch the UPS to **BYPASS**.



### **NOTE**

At this point the load is no longer protected against interruptions and disturbances of the mains supply.

5. Switch output and input switches to the **Off** position.
6. The UPS is now switched off, all LEDs are off and the load is supplied directly from the mains.

## ***4.7 Return from Maintenance Bypass Procedure***

1. Ensure all switches and circuit breakers upstream of the UPS are closed.
2. Switch both input switches to the **On** position.
3. Wait at least 30 seconds until the output voltage has stabilized (the yellow LED is lit).
4. Switch the Maintenance switch from **BYPASS** to **UPS** and replace the cover. The load is now supplied via electronic bypass.
5. Press the **Menu** button, select **Control** and press **OK**.
6. Select Turn **UPS ON/OFF** and press **OK**. The LCD displays 'Turn **UPS to ONLINE**'.
7. Press **OK** to switch on the inverter.

## ***4.8 Maintenance Switch, Off position***

Switch the maintenance switch to the **Off** position to disconnect the UPS output from output distribution.



### **WARNING**

**Connected loads are not supplied if the Maintenance Switch is set to the Off position.**

## 4.9 Functional Test



### NOTE

Supply to the load is not guaranteed during this test. The test should not be carried out if a critical load is connected to the UPS.

The GXT2-10000T230's controls permit testing the UPS to ensure that the load will be supplied in the event of a mains failure.

Before beginning, ensure that the batteries are fully charged.

Simulate a mains failure by interrupting the mains supply to the UPS. You can do this by switching off the input power circuit breaker on the rear panel of the UPS. If the mains supply to the GXT2-10000T230 is protected by an external circuit breaker, that circuit breaker may be opened to interrupt the mains supply and simulate a power failure.

The GXT2-10000T230 is operating properly and the batteries are charged if:

- An audible signal is heard at four-second intervals
- The UPSOn LED indicator turns off

When the interval between the audible signals decreases to one second, the UPS has battery reserve energy to supply the load for a maximum of two more minutes. After two minutes, the GXT2-10000T230 will automatically shut down.

If the batteries do not supply the load during the simulation, refer to "Troubleshooting" on page 45. To end the simulated mains failure, restore the input power supply to the UPS. The UPS is now ready for operation.



### NOTE

The batteries must be recharged before the complete emergency supply period is again available.

## 4.10 Emergency Switch Device

For safety reasons, an Emergency Power Off switch must be installed to shut down the UPS immediately. To do so, follow these steps:

1. Remove the connections between the ESD terminals on the rear of the UPS.
2. Connect an emergency switch (that will be closed under normal operating conditions and held open mechanically when activated).

Once the emergency situation causing the switch to open has been resolved, open all UPS switches (Input, Output and Battery) and restart the GXT2-10000T230 as described in "UPS Startup Procedure - Single Block" on page 32.

## 4.11 Remote Emergency Power Off

The UPS is equipped with an Emergency Power Off circuit. A factory-installed jumper allows the UPS to operate without an external shut-off switch.

If a Remote Emergency Power Off switch is required, a switch with normally closed contacts must be used.

Connect the switch contacts to the UPS by removing the factory-installed jumper as shown.

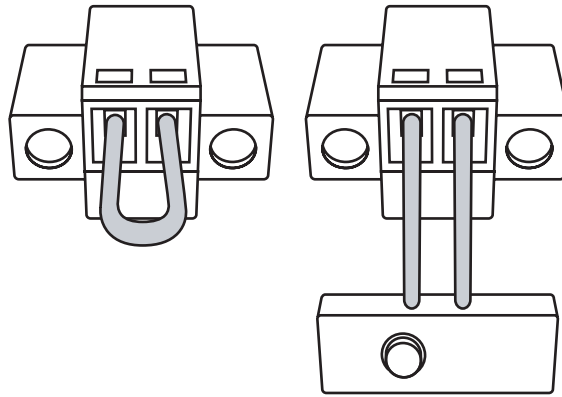

## 4.12 Self-Tests

### 4.12.1 Lamp Test



**NOTE**

This test involves putting the GXT2-10000T230 into bypass mode. The load is not protected against any mains disturbance or interruptions while the UPS is in bypass mode.

1. With the GXT2-10000T230 connected to the mains, press the **Menu** button, select **Control** and press **OK**.

Select **Turn UPS ON/OFF** and press **OK**.  
The LCD will show '**Turn UPS to BYPASS**'.

2. Press **OK** to switch the inverter to Bypass mode.  
A system confirmation beep will sound.

### 4.12.2 Battery Test



**NOTE**

During the test a beep will sound as though the device is operating in battery mode.

1. Press the **Menu** button.
2. Select **SETUP** and press **OK**.
3. Select **BATT TEST** and press **OK**.  
A system confirmation beep will sound and the load will be supplied by the battery.

If the test is successful, the BATT LED will stop flashing and the UPS will return to Line mode. If the UPS circuitry detects a battery malfunction, the system will display an alarm (see "Controls and Messages" on page 24)

See below for battery test report messages:.

Menu entry	Display
Battery test report	NoTest InProgress
	Test in progress
	Test OK!
	Test fail
	Test inhibit
	Test stop by user
	Test autonomy
	Test unknown



## 5 Maintenance

### ***5.1 Testing, replacement and disposal of batteries***

The UPS does not require maintenance by the user. When the batteries expire, they must be replaced by the appropriate customer service representative. For servicing, replace batteries with the same type and number of batteries or battery packs that were installed at the factory. For the battery type, see “Technical Data” on page 12.

Disposal of the UPS and batteries should be carried out by a certified disposal company - observe all local regulations and laws. Exhausted accumulator batteries are classified as harmful toxic waste and as such the law demands that they be disposed of by an authorized recycling centre.

The Liebert power protection customer service centre is fully equipped to deal with such batteries, in accordance with the law and with the greatest respect for the environment.

The typical battery life cycle is three to five years, at an ambient temperature of 25°C, but is also dependent on the frequency and duration of mains failures.

The battery test(see “Battery Test” on page 37) should be run periodically (every six to twelve months) to ascertain the general condition of the batteries and to ensure maximum run time.

#### **5.1.1 Easy Battery Replacement**

Open the front panel as shown below. Ensure that a certified service engineer is present to replace the batteries.

1. Open the battery tray DC connectors as shown
2. Remove the battery trays from the cabinet
3. Replace the old batteries with a new set. Replacement batteries must be the same type installed at the factory
4. Reconnect the battery cables

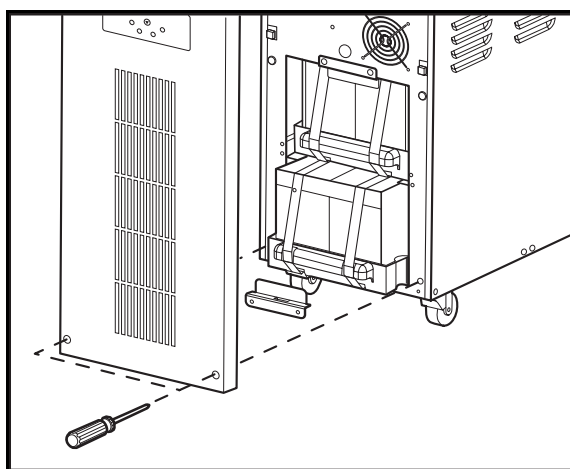

**Figure 5-1** Removing front panel and unlocking battery trays

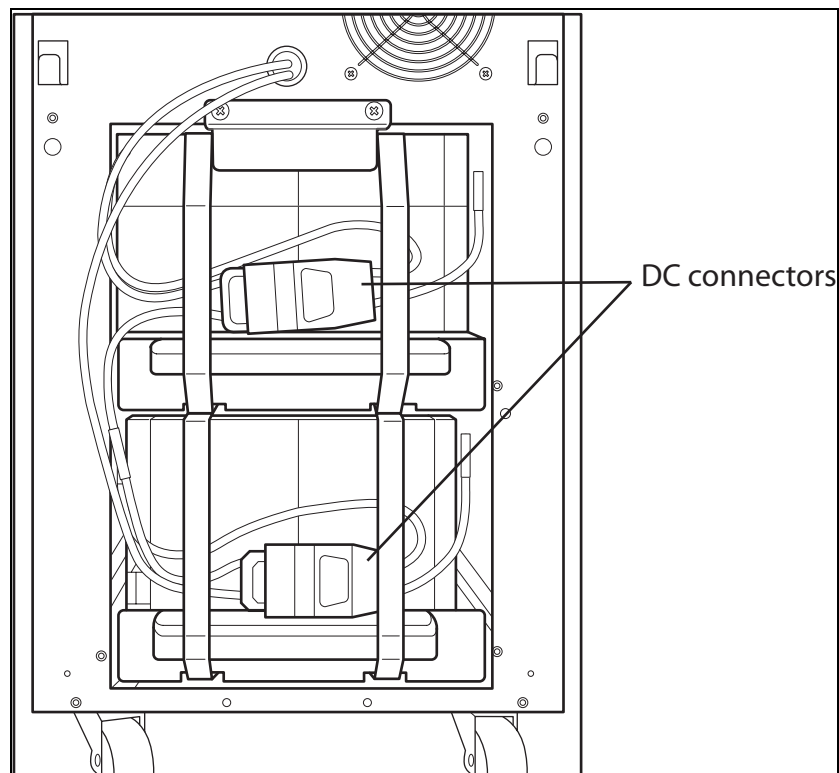

Figure 5-2 Disconnecting battery tray and battery packs

## 5.2 Storage

For extended storage at ambient temperatures cooler than 25°C (77°F), the batteries should be charged for five hours once every four months. At higher storage temperatures, Liebert recommends charging batteries for five hours every two months.

After five hours, disconnect from the mains supply or switch off the input miniature circuit breaker of the UPS. Then remove the UPS connections in the opposite sequence to that described in “Installation” on page 11.

Record the battery charging date in the vicinity of the UPS, for example, on its packaging.

## 5.3 Cleaning

1. Do not clean the UPS with scouring powder or solutions that may dissolve plastic.
2. Do not allow liquid to get inside the UPS.
3. Make sure that the air vents on the UPS are not obstructed. Remove dust from the air vents with a vacuum cleaner.
4. Clean the outside of the UPS by wiping the housing with a dry or slightly damp cloth.

## 6 Interfaces

### 6.1 Communications Interface Port

The GXT2-1000T230 has a standard DB-9 serial port female connector located on the rear of the unit. Several signals are provided on this port and are assigned as follows:

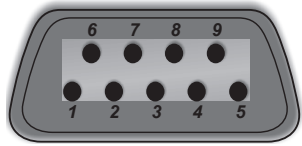
DB-9 Pin	Assignment Description	Pin Assignment
2	UPS TxD (typically RS-232 levels)	
3	UPS RxD (typically RS-(232 levels)	
5	Common	

### 6.2 Relay Contacts

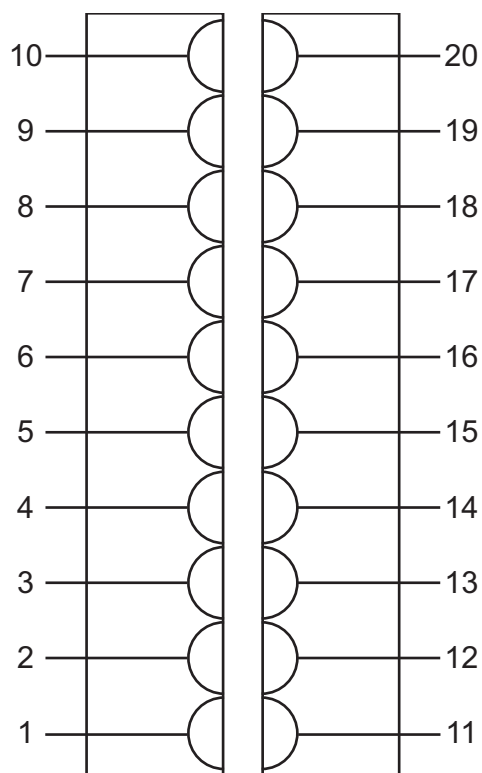

Relay Contacts Pin Information		
Pin	Function	Operation
1	UPS Fault	Closed if no UPS failiure
2	UPS Fault	Closed if UPS fails
3	Summary Alarm <sup>1</sup>	Closed if SUMMARY ALARM occurs

Relay Contacts Pin Information		
Pin	Function	Operation
4	Summary Alarm <sup>1</sup>	Closed if no alarm conditions occur
5	Signal Ground (for UPS Any Mode Shutdown)	
6	Common - Low Battery	
7	Low battery	Closed if battery is OK
8	Low Battery	Closed if LOW BATTERY warning occurs
9	JP01	Allows all 3 common relays to be tied together
10		
11	UPS Battery Mode Shutdown	Active when connected to pin 5
12	On UPS	Closed if UPS power in on (inverter).
13	On Battery	Closed if battery power is on (utility failure)
14	Common - UPS Fault, Summary Alarm, On UPS, On Battery, On Bypass	
15	Common - UPS Fault, Summary Alarm, On UPS, On Battery, On Bypass	
16	UPS Any Mode Shutdown (short to pin 5)	Turn UPS output OFF when connected to pin 5
17	On battery	Closed if battery power is not on (Status: OK)
18	On Bypass	Closed if BYPASS is on
19	JP02	Allows all 3 common relays and the Low Battery to be tied together <sup>2</sup>
20		

<sup>1</sup> A summary alarm occurs in any of the following situations :

- Utility power is outside the acceptable range (voltage and/or frequency)
- UPS is in BYPASS MODE (load is not on inverter power)
- UPS battery is LOW (<2 minutes of battery power remaining)
- UPS fault has occurred.

<sup>2</sup> This jumper should be removed if there is any external voltage source that may, intentionally or inadvertently, be connected to the relay contacts.

### 6.2.1 Pin 11 - Remote Shutdown on Battery

1. This pin is functional only when the UPS is in battery mode. If the UPS is being powered by the mains, Pin 11 will ignore any signal on this pin.
2. Pin 11 requires a ground signal to shut down. A signal for 1.5 seconds or greater is required to signal a shutdown. Signals for less than 1.5 seconds will be ignored. After Pin 11 receives a shutdown signal for 1.5 seconds, the command cannot be cancelled.
3. A battery shutdown signal on Pin 11 will NOT cause an immediate shutdown. A shutdown signal will start a two minute shutdown timer. The timer cannot be stopped. After two minutes, the UPS will shut down.
4. If the mains power returns during the two minute timer countdown, the shutdown timer will continue until the end of two minutes and the UPS will turn off. The UPS must remain off for at least ten seconds, even if AC input power returns before the UPS turns off. This serves to reset and restart the server. Whether the UPS turns back on when the power is restored depends on the auto-restart setting and whether it is enabled or disabled. If the auto-restart is disabled, the UPS will not restart after performing the two minute shutdown delay.

### 6.2.2 Pin 16 - Any Mode Shutdown

1. This pin will disable the UPS output power, both inverter and bypass.
2. Pin 16 requires a ground signal to shutdown.
3. An Any Mode Shutdown signal on Pin 16 will cause an immediate shutdown.
4. The UPS must be restarted from the front control panel after the ground signal is removed.

## 6.3 UPS Intelligent Communications

The GXT2-10000T230 is equipped with one Intellislot to provide advanced communication and monitoring options.

The Intellislot port closer to the corner of the UPS chassis is the serial card slot. This Intellislot port is used for the OCWEBCARD and the USBCARD.

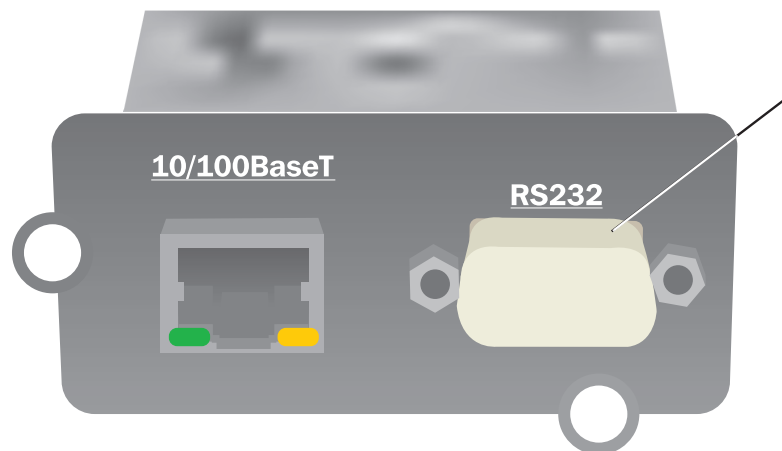

Liebert's MultiLink software continually monitors the UPS and can shut down your computer or server in the event of an extended power failure.

MultiLink can also be configured for use without the serial cable when the Intellislot SNMP/Web card is installed in the UPS. Additionally, MultiLink can be configured to coordinate shutdown across the network with other computers running MultiLink when you purchase a MultiLink License Kit. For more information about the Intellislot SNMP/Web Card and MultiLink license Kits, visit our Web-site ([www.liebert.com](http://www.liebert.com)) or contact your local dealer or Liebert representative.

Several optional cards are available for use in the Intellislot port of the GXT2-10000T230. The Intellislot SNMP/Web Card provides SNMP and Web-based monitoring and control of the UPS across the network.



### NOTE

The OCWEBCARD DB9 serial port cable should be used only for the initial card setup. Remove the cable after setup is complete.



### CAUTION

To maintain safety (SELV) barriers and for electromagnetic compatibility, signal cables should be segregated and run separate from all other power cables, where applicable.

## 7 Troubleshooting

If any technical problems should occur, check the following before contacting Liebert technical support:

1. Is the mains voltage present at the UPS input?
2. Has the input fuse blown or have the circuit breakers tripped?
3. Has the UPS startup procedure been followed correctly?

When contacting Liebert technical support, have the following information to hand:

- Device model number
- Serial number (from the nameplate)
- Exact description of the problem (what loads are being operated, does the problem occur regularly or sporadically, etc.)

For descriptions of the indicators mentioned in the following table, see 'Controls and Messages'.

**Table 7-1 Troubleshooting - errors and corrective action**

Problem	Possible cause	Solution
No display No alarm (UPS switched off)	Mains switched off	Switch on main breaker
	No mains voltage present	Have mains inspected by a qualified technician
	Input fuse blown or input circuit breaker tripped	Replace with fuse of same type or switch on circuit breaker. If the problem persists, contact technical support.
<b>UPS on</b> LED does not light up, alarm beeps sound at intervals	No mains voltage present	UPS operation control panel
<b>UPS on</b> LED does not illuminate when mains voltage present, audible alarm active at intervals	Input fuse defective or input circuit breaker tripped	Replace with fuse of same type or switch on circuit breaker. If the problem persists, contact technical support
<b>FAULT</b> LED illuminates, alarm sounding constantly	UPS error	Contact technical support
	Overheating	Decrease ambient temperature

**Table 7-1 Troubleshooting - errors and corrective action**

Problem	Possible cause	Solution
Autonomy less than specified	The fuse switch of the battery extension (s) is <b>'OPEN'</b> .	Contact technical support.
	Batteries are not fully charged	Charge batteries (see 'Batteries') and test backup time. If the problem persists, contact technical support.
	Batteries are defective	Contact technical support
	Charging device is defective	Contact technical support
'OVERLOAD' message displayed	Overload at UPS output	Reduce load to the permissible value
No communication between UPS and PC	Wrong serial connection cable	Check whether the correct cable has been used (standard modem/null modem cables are not permissible)
	Interface on the PC is being used by another process or is defective	Check whether other software/service is accessing the interface on the PC; try selecting a different serial interface
	Interference on the data cable	Lay cable differently/ Reinstall cabling

## 8 Options

### 8.1 External Battery Cabinets

To extend UPS autonomy in the event of mains interruption, optional external battery cabinets are available. The cabinets have the same dimensions, color scheme and design as the GXT2-10000T230.

For technical data about external battery cabinets see “Technical Data” on page 12.

For connection notices see “Connection data” on page 16.

### 8.2 Additional Battery Charger

An additional battery charger is available to support the GXT2-10000T230 in case of large battery applications. This board must be installed only if external battery cabinets are used.

Installation must be carried out by a qualified technician.

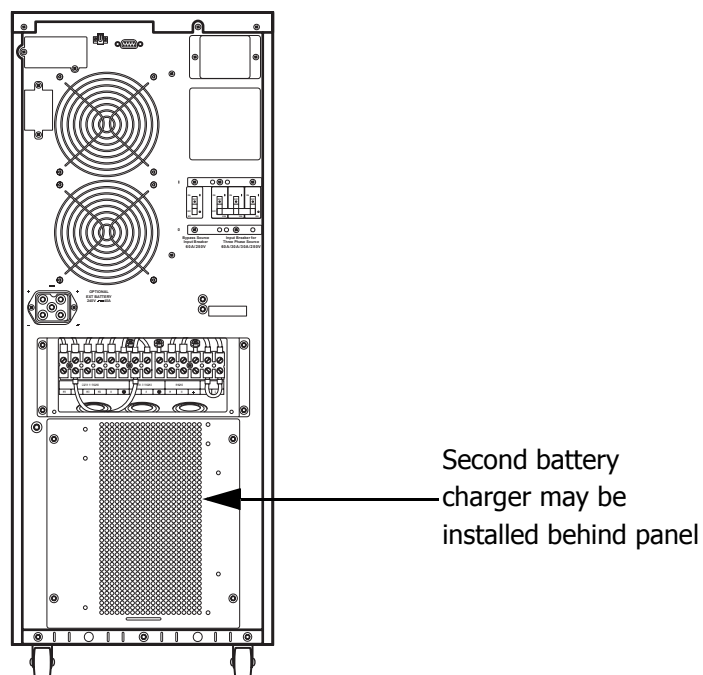

**Figure 8-1 Additional battery charger location**

The charger kit comprises of the following:

- Charger board
- Charger input and output cabling
- Top metal plate and handle
- Mounting material and screws
- Installation guide (English)

For installation information, refer to the Installation Guide.

When the additional charger is installed, the UPS battery calculation is deactivated.

### 8.3 Optional Interfaces

Refer to “Interfaces” on page 41 for details.

### 8.4 Battery Run Times

Typical battery run times for the GXT2-10000T230	Load %				
	10%	20%	30%	40%	50%
Internal battery	84	41	26	18	14
Internal battery + 1 external battery cabinet	291	171	95	69	53
Internal battery + 2 external battery cabinets	541	282	206	131	98
1 external battery cabinet	215	89	56	40	31
2 external battery cabinets	452	241	142	95	74

Typical battery run times for the GXT2-10000T230	Load %				
	60%	70%	80%	90%	100%
Internal battery	11	9	7	6	5
Internal battery + 1 external battery cabinet	42	35	29	26	23
Internal battery + 2 external battery cabinets	79	66	56	49	43
1 external battery cabinet	24	20	17	14	13
2 external battery cabinets	59	49	41	36	32



#### NOTE

Approximate discharge times are in minutes and at 77°F (25°C) with a 100% resistive load.



Power Availability

## GXT2 10000T230

### User Manual

#### The Company Behind the GXT2

With over a million installations around the globe, Liebert is the world leader in computer protection systems. Since its foundation in 1965, Liebert has developed a complete range of support and protection systems for sensitive electronics.

- Environmental systems - close control air conditioning from 1 to 60 tons
- Integrated systems that provide both environmental and power protection in a single, flexible package
- Monitoring and control - from systems of any size or location, on-site or remote
- Service and support through more than 100 service centers around the world and a 24/7 Customer Response Center

While every precaution has been taken to ensure the accuracy of the information presented in this manual, Liebert Corporation assumes no responsibility and takes no liability for damages resulting from the use of this information or for any errors or omissions.

© 2006 Liebert Corporation

All rights reserved throughout the world. Specifications are subject to change without notice.

® Liebert and the Liebert logo are registered trademarks of Liebert Corporation. All names referred to are trademarks or registered trademarks of their respective owners.

SL-23441 (12/05) Rev. 0

#### Technical Support/Service

##### Web Site

[www.liebert.com](http://www.liebert.com)

##### Monitoring

800-222-5877

[monitoring@liebert.com](mailto:monitoring@liebert.com)

Outside the US: 614-841-6755

##### Single phase UPS

800-222-5877

[upstech@liebert.com](mailto:upstech@liebert.com)

Outside the US: 614-841-6755

##### Three-Phase UPS

800-543-2378

[powertech@liebert.com](mailto:powertech@liebert.com)

##### Environmental Systems

800-543-2778

##### Outside the United States

614-888-0246

##### Locations

###### United States

1050 Dearborn drive

P.O. Box 29186

Columbus, OH 43229

###### Italy

Via Leonardo Da Vinci 8

Zona Industriale Tognana

35028 Piove Di Sacco (PD)

+39 049 9719 111

Fax: + 39 049 5841 257

###### Asia

7/F, Dah Sing Financial Centre

108 Gloucester Road, Wanchai

Hong Kong

852 25722201

Fax: 852 28029250



